

CHECK VALVE REVERSE GUIDED POPPET

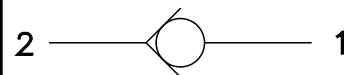

TORQUE:

Steel = 95/100 Ft-Lb. [129/136 Nm]
Aluminum = 70/75 Ft-Lb. [95/102 Nm]

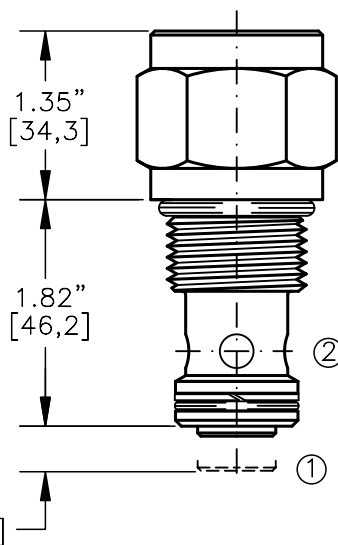
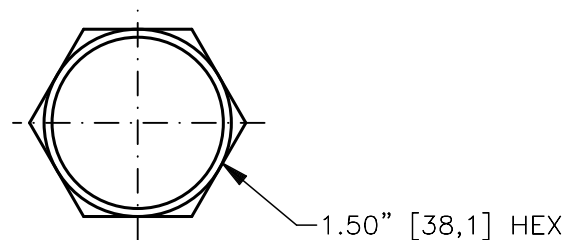
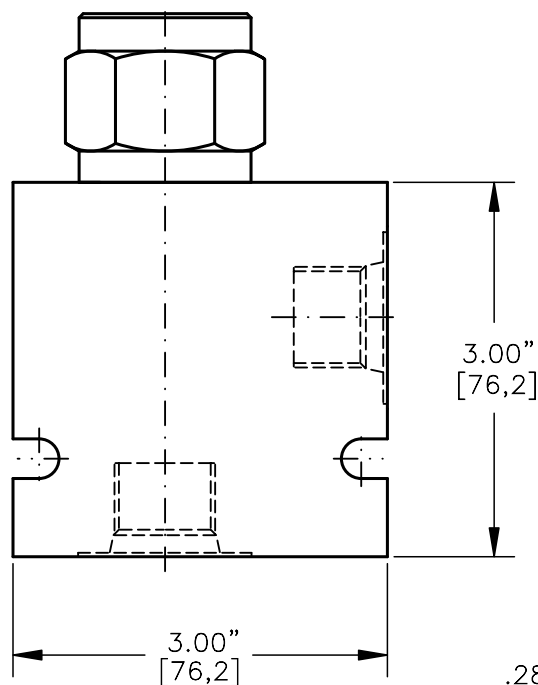

FOR ALUMINUM OR STEEL VALVE HOUSING CONFIGURATIONS SEE PAGE 0-014.1

CVRP-16-X-X-XXX

BASIC

SIZE

16 = 1.312"-12 UNF

SEALS

N = BUNA "N"
V = VITON

PORTS

0 = CARTRIDGE ONLY
04BX = G 1/2" BSPP
06BX = G 3/4" BSPP
10TX = SAE - #10
12TX = SAE - #12

"A" - ALUM. HOUSING
"S" - STEEL HOUSING

CRACK PRESSURE

005 = 5 PSI
015 = 15 PSI
030 = 30 PSI
060 = 60 PSI
120 = 120 PSI

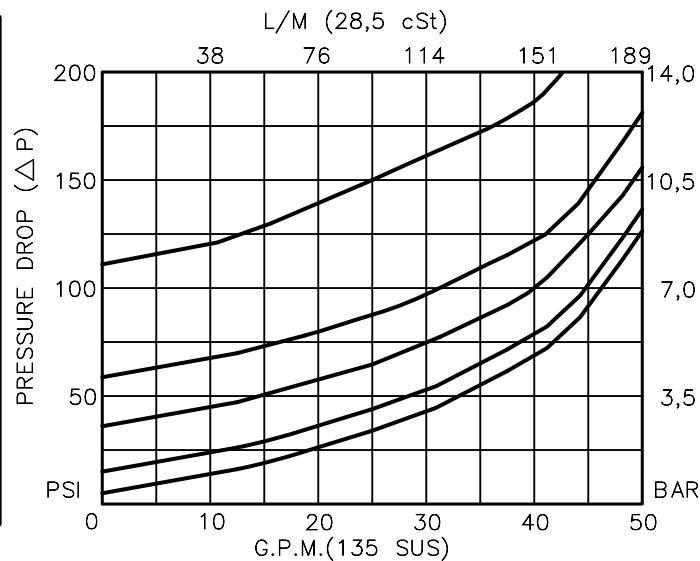

CHECK VALVE REVERSE GUIDED POPPET

DESCRIPTION

This unit is a SCREW IN, cartridge type, guided poppet, hydraulic check valve, used as a blocking or load holding device for high pressure applications.

OPERATIONS

This valve allows free flow from port 2 to port 1 and blocks flow from port 1 to port 2 or holding a load.

FEATURES AND BENEFITS

Wide selection of bias springs allows flexibility for back-pressure application.

All external carbon steel parts are plated for longer life against the elements.

All cartridge valves are 100% functionally tested.

Industry common cavity.

SPECIFICATIONS

OPERATING PRESSURE: 5,000 PSI [350 Bar]

PROOF PRESSURE: 10,000 PSI [700 Bar]

FLOW: 50.0 GPM [190 l/m] nominal. See performance chart.

INTERNAL LEAKAGE: 5 drops per minute maximum @ 5,000 PSI [350 Bar]

VALVE HOUSINGS: 2500 PSI [175 Bar] = Aluminum – Anodized.

5000 PSI [350 Bar] = Steel – Unplated.

OPERATING TEMPERATURE: -40° to +250° F. [-40° to +120° C.]

OPERATING MEDIA: All general purpose hydraulic fluids such as MIL-H-5606, SAE-#10, SAE-#20, etc.

INSTALLATION: No restrictions.

SEAL KIT: SKN-1621 Buna "N"

SKV-1621 Viton

WEIGHT: 0.82 lb [0.37 kg] cartridge only.

VALVE CAVITY: #C1620, See Page 0-014.0.

info.el@bucherhydraulics.com

www.bucherhydraulics.com/commoncavity

© 2015 by Bucher Hydraulics, Inc., 2545 Northwest Parkway, Elgin, Illinois 60124, USA

All rights reserved.

Data is provided for the purpose of product description only, and must not be construed as warranted characteristics in the legal sense. The information does not relieve users from the duty of conducting their own evaluations and tests. Because the products are subject to continual improvement, we reserve the right to amend the product specifications contained in this catalogue.