

Explosion Proof, 4/2 and 4/3, Directional Control Valve, Solenoid Operated

RPEX3-06

Size 06 (D03) • Q_{max} 60 l/min (16 GPM) • p_{max} 350 bar (5100 PSI)

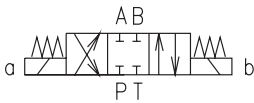
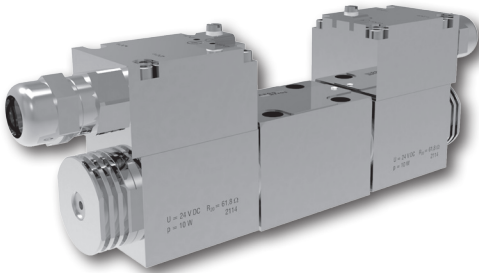

Technical Features

- › Valve and solenoid design prevents a surface temperature capable of igniting
- › Solenoid coil in acc. with directive 94/9/EC (ATEX) for explosion-hazard zones
- › Explosion protection for gas, dust and mining, Solutions for all zones
- › Encapsulation enclosure solenoid version
- › Direct acting, directional control valve with subplate mounting surface acc. to ISO 4401, DIN 24340 (CETOP 03) standards
- › High transmitted hydraulic power up to 350 bar with optimized design to minimize the flow pressure drop All ports may be fully pressurised
- › Five chambers housing design with reduced hydraulic power dependence on fluid viscosity
- › Wide range of manual overrides available
- › Coil interchangeability with all Argo-Hytos ATEX/IECEx product line
- › In the standard version, the valve is zinc coated for 520 h protection acc. to ISO 9227

ATEX/IECEx Classification

The valves equipped with explosion proof solenoids are available with following certifications and protection modes:

	EPS14ATEX1744 X	IECEx EPS14.0064 X
AC	I M2 Ex mb I Mb	Ex mb I Mb
	II 2G Ex mb IIB T4, T5, T6 Gb	Ex mb IIB T4, T5, T6 Gb
	II 2D Ex mb IIIC T135°C, T100°C, T85°C Db	Ex mb IIIC T135°C, T100°C, T85°C Db
DC	I M2 Ex e mb I Mb	Ex e mb I Mb
	II 2G Ex e mb IIB T4, T5, T6 Gb	Ex e mb IIB T4, T5, T6 Gb
	II 2D Ex tb IIIC T135°C, T100°C, T85°C Db	Ex tb IIIC T135°C, T100°C, T85°C Db

ISO 4401-03-02-0-05

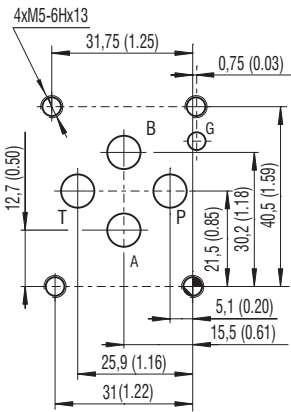

Ports P, A, B, T - max. Ø7.5 mm (0.29 in)

Technical Data

Valve size		06 (D03)	
Max. flow	l/min (GPM)	60 (15.9)	
Max. operating pressure at ports P, A, B	bar (PSI)	350 (5080)	
Max. operating pressure at ports T	bar (PSI)	210 (3050)	
Pressure drop	bar (PSI)	see Δp-Q characteristics	
Fluid temperature range (NBR)	°C (°F)	-30 ... +70 (-22 ... +158)	
Max. switching frequency	1/h	15 000	
Switching time ON at v=32 mm ² /s (156 SUS)	ms	AC: 30 ... 40	DC: 30 ... 50
Switching time OFF at v=32 mm ² /s (156 SUS)	ms	AC: 30 ... 70	DC: 10 ... 50
Weight	valve with 1 solenoid	2.52 (5.56)	
	valve with 2 solenoids	3.97 (8.75)	
Technical Data - Explosion proof Solenoid			
Voltage type		AC 50/60 HZ	DC
Available voltages	V	110, 230	12, 24, 48, 110
Available nominal power	W	10	
Supply voltage tolerance	%	AC: ±10	DC: ±10
Duty cycle		(100 % ED)	
Enclosure type of the Solenoid to EN 60529		IP 65	
Ambient temperature range			
Temperature class / Nominal power	T4-10 W / 18 W	°C (°F)	-30 ... +70/60 (-22 ... +158/140)
	T5-10 W		-30 ... +55 (-22 ... +131)
	T6-10 W		-30 ... +45 (-22 ... +113)
	Data Sheet	Type	
General information	GI_0060	products and operating conditions	
Coil types / Connectors	C_8007 / K_8008	74 EX 18	
Mounting surface	SMT_0019	Size 06	
Subplates	Subplates_0002		
Spare parts	SP_8010		

Samples of Marking

Marking of Solenoid

74 EX18 046A A024
 UN=24VDC Ig=0,34A R20=61,8Ω
 IP65 CE 0408

EPS14ATEX1744 X
 I M2 Ex e mb I Mb
 II 2G Ex e mb IIB T4 Gb
 II 2D Ex tb IIIC T135°C Db
 IECEX EPS14.0064 X
 Ex e mb I Mb
 Ex e mb IIB T4 Gb
 Ex tb IIIC T135°C Db

1234/01
 02/14

-40 °C ≤ Tamb ≤ +70 °C

74 EX18 046A A024
 UN=24VDC Ig=0,34A R20=61,8Ω
 IP65 CE 0408

EPS14ATEX1744 X
 I M2 Ex e mb I Mb
 II 2G Ex e mb IIB T6 Gb
 II 2D Ex tb IIIC T85°C Db
 IECEX EPS14.0064 X
 Ex e mb I Mb
 Ex e mb IIB T6 Gb
 Ex tb IIIC T85°C Db

1234/01
 02/14

-40 °C ≤ Tamb ≤ +45 °C

Marking of Body

A T B
 ARGO HYTOS
 15711700 0810/1234567
 RPEX3-063Z11/02400A4
 Ex II 2GD c T4
 I M2 c
 p max P,A,B=320 bar
 p max T=210 bar
 Made in Czech Republic
 P

Group I (mining)

Ex ATEX mark of conformity to the 94/9CE directive and to the technical norms.
 I Group I for mines
 M2 High protection - equipment category
 Ex e mb Type of protection: e - increased safety, mb - encapsulated
 I Gas group (Methane)
 Mb Equipment protection level - High level protection for explosive atmosphere

Group II

Ex ATEX mark of conformity to the 94/9CE directive and to the technical norms.
 II 2G Solenoid for surface plants with Gas and Vapors environment for zones 1 and 2.
 II 2D Solenoid for surface plants with Dust environment for zones 21 and 22.
 Ex e mb Type of protection: e - increased safety, mb - encapsulated
 Ex tb Type of protection: tb - protection by enclosure
 IIB Equipment suitable for substances (gas) of group IIB
 IIIC Equipment suitable for conductive dust (Specific resistance $\rho \leq 10^3 \Omega m$)
 T6/T4 Temperature class (maximum solenoid surface temperature)
 T85/T135 Maximum solenoid surface temperature
 Gb Equipment protection level - High level protection for explosive Gas atmosphere
 Db Equipment protection level - High level protection for explosive Dust atmosphere

Manual Override in millimeters (inches)

No designation - standard	N7 - detent assembly	N9 - without manual override

In the case of solenoid malfunction or power failure, the spool of the valve can be shifted by manual override.
 For other manual overrides consult our technical department.

Dimensions in millimeters (inches)

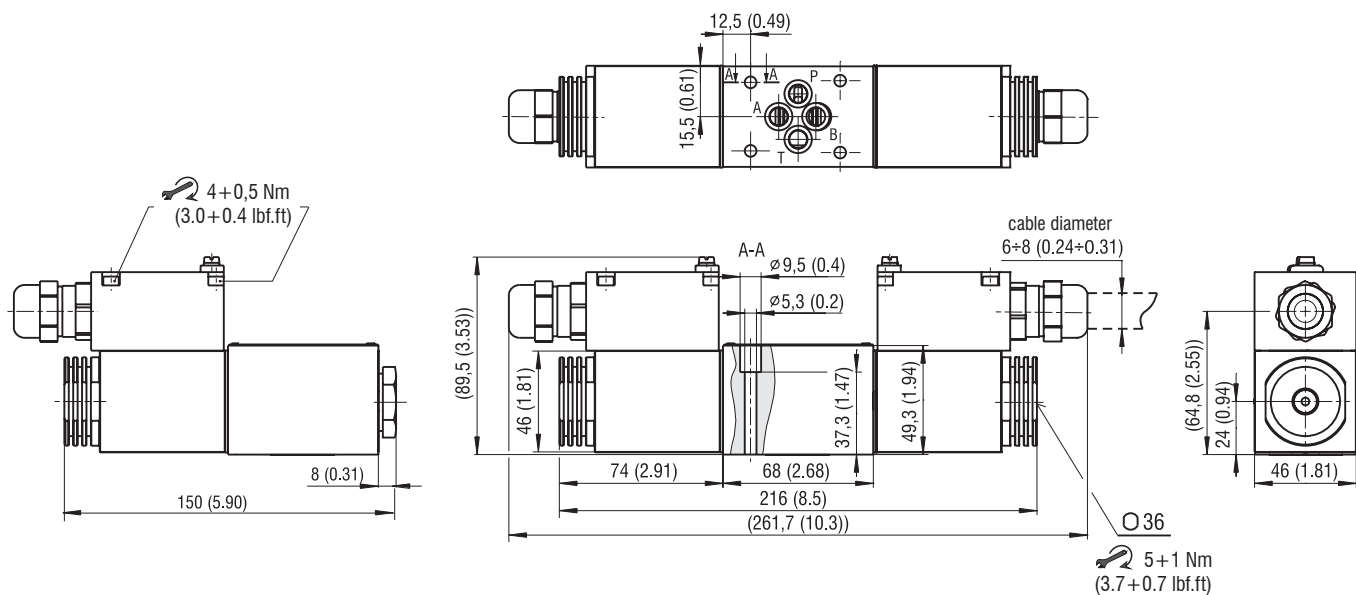

Information for Customers

Initial installation

- › The ambient temperature range shall not overstep the temperatures given in the chapter Technical Data - Explosion proof solenoid (page 1). The maximum temperature of the medium (generally hydraulic fluid) shall not exceed 70 °C (158 °F).
- › It is the users duty to ensure free and unhindered heat emission during operation. This means that the solenoid shall neither be covered nor stored immediately adjacent to heat sources (e.g. fan heaters) during operation.
- › Care is to be given that the solenoid is not subjected to direct sunlight during operation.

Installation notice - installation, mounting, demounting

- › Installing the type V DC for temperature class T4 a cable with an ambient operating temperature of at least +105 °C (+221 °F) is to be used. For T5 and T6 a cable with an ambient operating temperature of at least +90 °C (+194 °F) is sufficient. The fastening torque on the cable gland depends of the used cable and is to be determined by installing user.
- › When installing the V DC solenoid type, please note the fastening torque of the screws (4 Nm or 2.95 lbf.ft) and of the Connection box (0.4 Nm or 0.30 lbf.ft).
- › When installing the V DC solenoid type, an appropriate cable shoe M3 - 0.75 mm² (with an ambient operating temperature of at least +105 °C or +221 °F) is to be used.
- › The user has to safeguard each solenoid with a fuse: $I_n \leq 3I_G$, with tigger characteristic "slow blow". (I_G values see Operating Instructions HA 4090 - Table 2). The breaking capacity of the fuse link has to be stronger than the max short circuit current at the users operating area.
- › EX-secured components must be used during mounting in case the fuse and/or the interface are within the EX-range.
- › In addition, the solenoid may be connected to ground via the purpose-built ground clamp an the connector casing.

Safety notice - please read carefully

- › In case the solenoid shows any signs of a defect, malfunctioning or external damage (including corrosion), the device must immediately be taken out of operation.
- › Any deposits on the surface of the device shall not obstruct heat emission.
- › To maintain legibility of the date plate, the solenoid must not be coated.

Caution

- › Always disconnect the solenoid from the power supply before any maintenance or other work on it.
- › Always exchange the complete solenoid. Do not try to repair the solenoid.
- › In no case shall any changes be made to the solenoid or the connecting cable.
- › Demount the solenoid only in secure areas (not in EX-areas). If this is not possible, the solenoid must cool for 10 minutes minimum.

