

HDB SERIES

Decompression block couplers

INTRODUCTION

Holmbury's HDB Series is a block coupler designed for the quick changeover of hydraulic attachments for skid steer loaders, compact loaders, backhoe loaders and compact utility vehicles. The decompression feature enables the operator to alleviate trapped pressure, allowing the quick and easy connection of various attachments.

CONSTRUCTION

- HQ Series couplers are carbon steel with zinc nickel plating (1200 hours with no red rust in salt spray tests)
- Block body is ductile cast iron
- Fitted with Nitrile and PTFE seals

FEATURES

- Operator friendly decompression system allows for easy connection and disconnection with trapped residual pressure
- Pull activation feature prevents accidental system decompression
- All couplers are flat face and are designed to the ISO 16028 Standard
- Low profile coupler design minimizes side loading
- Coupler arrangement can be ordered in 1/2" (Size 12) for standard flow or 3/4" (Size 19) for high flow applications
- Case drain coupler is standard 3/8" (Size 10)
- Low cost replacement couplers
- Accessible design allows for servicing of internal components

ORDER CODES



SPECIFICATIONS

- Operating temperatures (With Nitrile seals): -40°C (-40°F) to 106°C (223°F).
- Maximum working pressure 350 bar
- Flow rate at 2 bar delta P 1/2" (size 12) 76.4 L/Min & 3/4" (size 19) 136 L/Min
- Decompression force 130 Nm at 275 bar trapped pressure

APPLICATIONS

- Quick changeover of construction equipment attachments
- Skid steer loaders
- Track loaders
- Excavators
- Compact loaders
- Utility vehicles

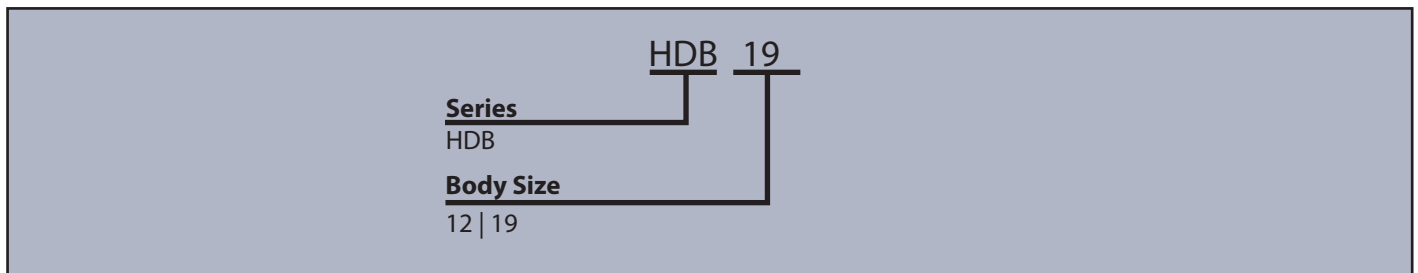

DRAWING & DIMENSIONS

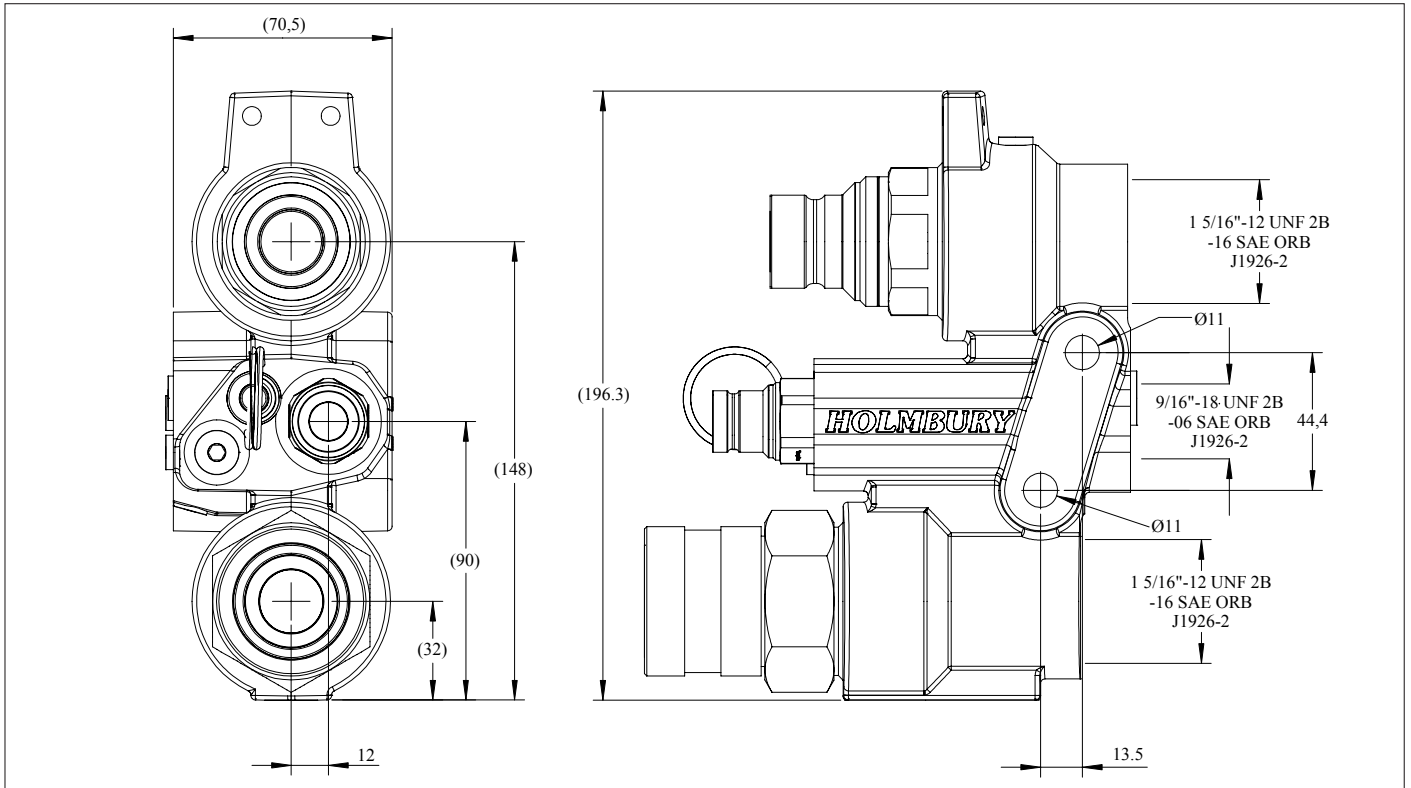

PRESSURE DROP CHARACTERISTICS

