



Shell & Tube Application Request: (For liquid to liquid heat exchangers)

For CS-STC Series

Email form to: sales@aihti.com or engineering@aihti.com or fax to 434-757-1810
 Please download form to fill it out and either email or fax in.

Contact Name _____ Telephone _____ Date _____

Company Name _____ Email _____

Address: _____ Fax _____

Hot Side

Cold Side

Fluid Type _____

Fluid Type _____

Density _____ lb/ft³

Density _____ lb/ft³

Viscosity _____ cP

Viscosity _____ cP

If available:

Conductivity _____ Btu/hr.ft.°F

If available:

Conductivity _____ Btu/hr.ft.°F

Specific Heat _____ Btu/lb.°F

Specific Heat _____ Btu/lb.°F

1. Flow Rate _____

1. Flow Rate _____

2. Temperature In _____

2. Temperature In _____

3. Desired Temperature Out _____

Maximum Allowable Pressure Drop:

4. Heat Load _____

Hot Side _____ Cold Side _____

To properly size the heat exchanger we need 3 of the 4 parameter on the Hot Side and 2 on the Cold Side.

Shell Material Construction:

Tube Material Construction:

Brass Steel Stainless Steel

Copper 90/10 Copper Nickel Stainless Steel

ASME Code and Certified Yes No

Require All Stainless Steel Heat Exchanger Yes No

Comment: _____

American Industrial Heat Transfer Inc.

Manufacturer of Quality Heat Exchangers



www.aihti.com

CS - STC SERIES



SINGLE
PASS

TWO
PASS

FOUR
PASS

Fixed Tube Bundle / Liquid Cooled

HEAT EXCHANGERS

- Computer generated data sheet available for any application
- Steel or stainless steel construction.
- Operating pressure for tubes 150 PSI
- Operating pressure for shell 300 PSI.
- Operating temperature 300 °F.
- Can be customized to fit any applications.
- Cools: Fluid power systems, rock crushers, presses, shears, lubrication equipment for paper machinery, gear drives, marine transmissions, etc.
- As an option, available in ASME code and certified

note: AIHTI reserves the right to make reasonable design changes without notice.

Copyright © 2017 American Industrial Heat Transfer, Inc. 355 American Industrial Drive LaCrosse, VA 23950 tel: 434-757-1800 fax: 434-757-1810 email: sales@aihti.com

CS & STC Series *overview*



CS SERIES

Fixed tube construction heat exchangers with NPT connections. Made of steel with copper cooling tubes and cast iron end bonnets. Standard sizes from 3" through 8" diameters. Standard one, two, and four pass models are available. Options include 90/10 copper nickel and 316 stainless steel cooling tube, and zinc anodes. Can be customized to fit your requirements.



STC SERIES

Similar in design to CS series with fixed tube construction and NPT connections made of 316 stainless steel. Standard sizes from 3" through 8" diameters. Standard one, two, and four pass models are available. Larger diameter units available upon request. Can be customized to fit your requirements.

In applications where water is not available for cooling (see page 155)



AC-ACF-ACHM Series

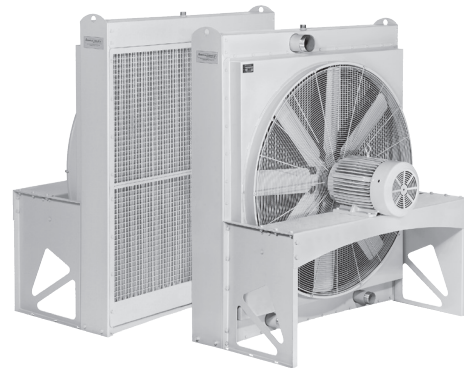

AOCS Series



AOCH Series

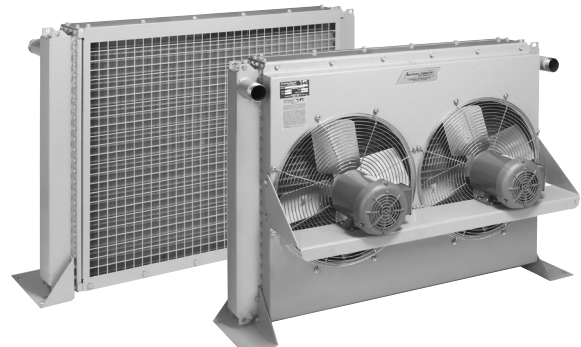

EOC - EOCF Series

CS & STC Series overview

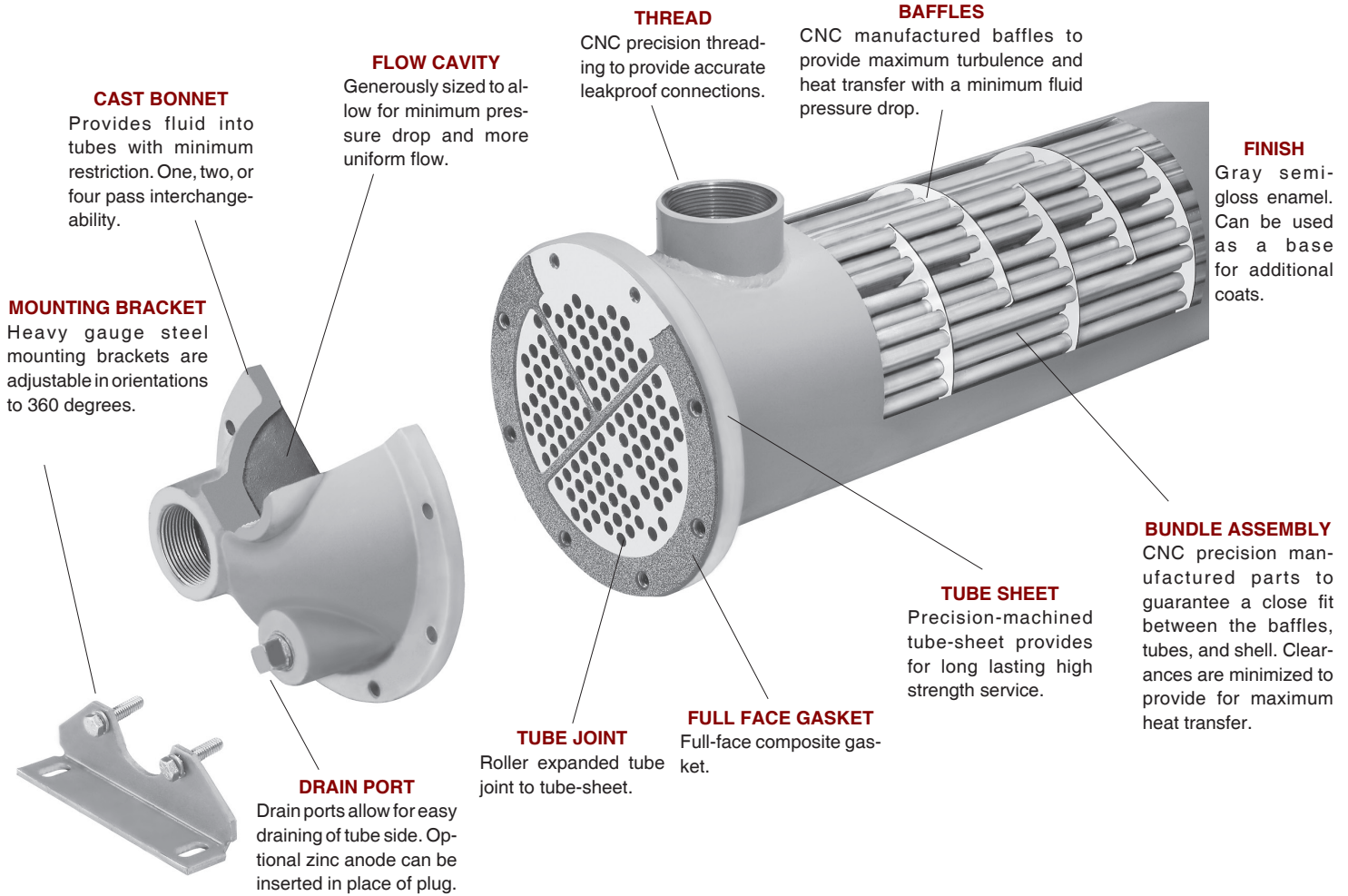

Example Model

UNIT CODING

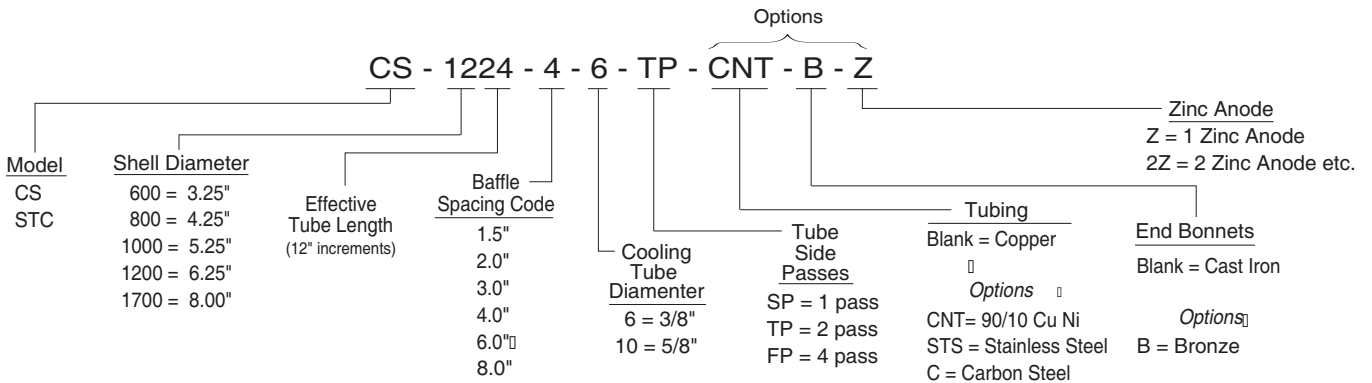

Standard Model	CS Series	STC Series	Standard Unit Ratings
Shell	Steel	316 Stainless Steel	Operating Pressure Tubes 150 psig Operating Pressure Shell 300 psig Operating Temperature 300 °F
Tubes	Copper	316 Stainless Steel	
Baffle	Aluminum / Steel	316 Stainless Steel	
Tube Sheet	Steel	316 Stainless Steel	
End Bonnets	Cast Iron	316 Stainless Steel	
Mounting Brackets	Steel	Steel	
Gasket	Hypalon Composite	Hypalon Composite	

note: AIHTI reserves the right to make reasonable design changes without notice.

CS & STC Series selection

STEP 1: Calculate the heat load

The heat load in BTU/HR or (Q) can be derived by using several methods. To simplify things, we will consider general specifications for hydraulic system oils and other fluids that are commonly used with shell & tube heat exchangers.

Terms			
GPM	= Gallons Per Minute	Kw	= Kilowatt (watts x 1000)
CN	= Constant Number for a given fluid	T _{in}	= Hot fluid entering temperature in °F
ΔT	= Temperature differential across the potential	T _{out}	= Hot fluid exiting temperature in °F
PSI	= Pounds per Square Inch (pressure) of the operating side of the system	t _{in}	= Cold fluid temperature entering in °F
MHP	= Horsepower of the electric motor driving the hydraulic pump	t _{out}	= Cold fluid temperature exiting in °F
		Q	= BTU / HR

For example purposes, a hydraulic system has a 125 HP (93Kw) electric motor installed coupled to a pump that produces a flow of 80 GPM @ 2500 PSIG. The temperature differential of the oil entering the pump vs exiting the system is about 5.3°F. Even though our return line pressure operates below 100 psi, we must calculate the system heat load potential (Q) based upon the prime movers (pump) capability. We can use one of the following equations to accomplish this:

To derive the required heat load (Q) to be removed by the heat exchanger, apply ONE of the following. Note: The calculated heat loads may differ slightly from one formula to the next. This is due to assumptions made when estimating heat removal requirements. The factor (v) represents the percentage of the overall input energy to be rejected by the heat exchanger. The (v) factor is generally about 30% for most hydraulic systems, however it can range from 20%-70% depending upon the installed system components and heat being generated (ie. servo valves, proportional valves, etc...will increase the percentage required).

FORMULA	EXAMPLE	Constant for a given fluid (CN)
A) Q = GPM x CN x actual ΔT	A) Q = 80 x 210 x 5.3°F = 89,040 BTU/HR	1) Oil CN = 210
B) Q = [(PSI x GPM) / 1714] x (v) x 2545	B) Q = [(2500x80)/1714] x .30 x 2545 = 89,090 BTU/HR	2) Water..... CN = 500
C) Q = MHP x (v) x 2545	C) Q = 125 x .30 x 2545 = 95,347 BTU/HR	3) 50% E. Glycol..... CN = 450
D) Q = Kw to be removed x 3415	D) Q = 28 x 3415 = 95,620 BTU/HR	
E) Q = HP to be removed x 2545		

STEP 2: Calculate the Mean Temperature Difference

When calculating the MTD you will be required to choose a liquid flow rate to derive the Cold Side ΔT. If your water flow is unknown you may need to assume a number based on what is available. As a normal rule of thumb, for oil to water cooling a 2:1 oil to water ratio is used. For applications of water to water or 50 % Ethylene Glycol to water, a 1:1 ratio is common.

FORMULA	EXAMPLE
HOT FLUID ΔT = $\frac{Q}{CN \times GPM}$ Oil	ΔT = $\frac{89,090 \text{ BTU/hr (from step 1, item B)}}{210 \text{ CN} \times 80 \text{ GPM}} = 5.3^\circ\text{F} = \Delta T \text{ Rejected}$
COLD FLUID Δt = $\frac{\text{BTU / hr}}{\text{CN} \times \text{GPM}}$ Water	Δt = $\frac{89,090 \text{ BTU/hr}}{500 \text{ CN} \times 40 \text{ GPM (for a 2:1 ratio)}} = 4.45^\circ\text{F} = \Delta T \text{ Absorbed}$
T _{in} = Hot Fluid entering temperature in degrees F	T _{in} = 125.3 °F
T _{out} = Hot Fluid exiting temperature in degrees F	T _{out} = 120.0 °F
t _{in} = Cold Fluid entering temperature in degrees F	t _{in} = 70.0 °F
t _{out} = Cold Fluid exiting temperature in degrees F	t _{out} = 74.5 °F
$\frac{T_{out} - t_{in}}{T_{in} - t_{out}} = \frac{S[\text{smaller temperature difference}]}{L[\text{larger temperature difference}]} = \left(\frac{S}{L}\right)$	$\frac{120.0^\circ\text{F} - 70.0^\circ\text{F} = 50.0^\circ\text{F}}{125.3^\circ\text{F} - 74.5^\circ\text{F} = 50.8^\circ\text{F}} = \frac{50.0^\circ\text{F}}{50.8^\circ\text{F}} = .984$

STEP 3: Calculate Log Mean Temperature Difference (LMTD)

To calculate the LMTD please use the following method;

L = Larger temperature difference from step 2.

M = S/L number (LOCATED IN TABLE A).

LMTD_i = L x M

LMTD_i = 50.8 x .992 (FROM TABLE A) = 50.39

To correct the LMTD_i for a multipass heat exchangers calculate R & K as follows:

FORMULA	EXAMPLE	Locate the correction factor CF _B (FROM TABLE B)
$R = \frac{T_{in} - T_{out}}{t_{out} - t_{in}}$	$R = \frac{125.3^\circ\text{F} - 120^\circ\text{F}}{74.5^\circ\text{F} - 70^\circ\text{F}} = \frac{5.3^\circ\text{F}}{4.5^\circ\text{F}} = \{1.17=R\}$	LMTD _c = LMTD _i x CF _B LMTD _c = 50.39 x 1 = 50.39
$K = \frac{t_{out} - t_{in}}{T_{in} - t_{in}}$	$K = \frac{74.5^\circ\text{F} - 70^\circ\text{F}}{124.5^\circ\text{F} - 70^\circ\text{F}} = \frac{4.5^\circ\text{F}}{55.4^\circ\text{F}} = \{0.081=K\}$	

STEP 4: Calculate the area required

$$\text{Required Area sq.ft.} = \frac{Q \text{ (BTU / HR)}}{\text{LMTD}_c \times U \text{ (FROM TABLE C)}} = \frac{89,090}{50.39 \times 100} = 17.68 \text{ sq.ft.}$$

STEP 5: Selection

a) From TABLE E choose the correct series size, baffle spacing, and number of passes that best fits your flow rates for both shell and tube side. Note that the tables suggest minimum and maximum information. Try to stay within the 20-80 percent range of the indicated numbers.

Example

Oil Flow Rate = 80 GPM = Series Required from Table E = **1200 Series**
 Baffle Spacing from Table E = **4**
 Water Flow Rate = 40 GPM = Passes required in 1200 series = **4 (FP)**

b) From TABLE D choose the heat exchanger model size based upon the sq.ft. or surface area in the series size that will accommodate your flow rate.

Example

Required Area = 17.68sq.ft. Closest model required based upon sq.ft. & series = **CS - 1224 - 4 - 6 - FP**

If you require a computer generated data sheet for the application, or if the information that you are trying to apply does not match the corresponding information, please contact our engineering services department for further assistance.

TABLE A- FACTOR M/LMTD = L x M

S/L	M	S/L	M	S/L	M	S/L	M
.01	.215	.26	.541	.50	.721	.75	.870
.02	.251	.27	.558	.52	.734	.77	.879
.03	.277	.28	.566	.53	.740	.78	.886
.04	.298	.29	.574	.54	.746	.79	.890
.05	.317	.30	.582	.55	.753	.80	.896
.06	.334	.31	.589	.56	.759	.81	.902
.07	.350	.32	.597	.57	.765	.82	.907
.08	.364	.33	.604	.58	.771	.83	.913
.09	.378	.34	.612	.59	.777	.84	.918
.10	.391	.35	.619	.60	.783	.85	.923
.11	.403	.36	.626	.61	.789	.86	.928
.12	.415	.37	.634	.62	.795	.87	.934
.13	.427	.38	.641	.63	.801	.88	.939
.14	.438	.39	.648	.64	.806	.89	.944
.15	.448	.40	.655	.65	.813	.90	.949
.16	.458	.41	.662	.66	.818	.91	.955
.17	.469	.42	.669	.67	.823	.92	.959
.18	.478	.43	.675	.68	.829	.93	.964
.19	.488	.44	.682	.69	.836	.94	.970
.20	.497	.45	.689	.70	.840	.95	.975
.21	.506	.46	.695	.71	.848	.96	.979
.22	.515	.47	.702	.72	.852	.97	.986
.23	.524	.48	.709	.73	.858	.98	.991
.24	.533	.49	.715	.74	.864	.99	.995

TABLE D- Surface Area

Model Number	Surface Area in Sq.ft.			Model Number	Surface Area in Sq.ft.		
	1/4" O.D Tubing CODE 4	3/8" O.D Tubing CODE 6	5/8" O.D Tubing CODE 10		1/4" O.D Tubing CODE 6	3/8" O.D Tubing CODE 6	5/8" O.D Tubing CODE 10
CS-614	4.6	-	-	CS-1236	50.63	35.33	17.66
CS-624	7.9	-	-	CS-1248	67.51	47.10	23.55
CS-636	11.5	-	-	CS-1260	84.39	58.88	29.44
				CS-1272	101.27	70.65	35.33
CS-814	8.3	-	-	CS-1284	118.14	82.43	41.21
CS-824	14.1	-	-	CS-1296	135.02	94.20	47.10
CS-836	21.2	-	-				
CS-848	28.3	-	-	CS-1724	58.61	43.96	23.55
				CS-1736	87.92	65.94	35.33
CS-1014	13.74	9.16	4.58	CS-1748	117.23	87.92	47.10
CS-1024	23.55	15.70	7.85	CS-1760	146.53	109.90	58.88
CS-1036	35.33	23.55	11.78	CS-1772	175.84	131.88	70.65
CS-1048	47.10	31.40	15.70	CS-1784	205.15	153.86	82.43
CS-1060	58.88	39.25	19.63	CS-1796	234.45	175.84	94.20
				CS-17108	263.76	197.82	105.98
CS-1224	33.76	23.55	11.78	CS-17120	293.07	219.80	117.75

TABLE B- LMTD correction factor for Multipass Exchangers

	.05	.1	.15	.2	.25	.3	.35	.4	.45	.5	.6	.7	.8	.9	1.0
.2	1	1	1	1	1	1	1	.999	.993	.984	.972	.942	.908	.845	.71
.4	1	1	1	1	1	1	.994	.983	.971	.959	.922	.855	.70		
.6	1	1	1	1	1	.992	.980	.965	.948	.923	.840				
.8	1	1	1	1	.995	.981	.965	.945	.916	.872					
1.0	1	1	1	1	.988	.970	.949	.918	.867	.770					
2.0	1	1	.977	.973	.940	.845	.740								
3.0	1	1	.997	.933	.835										
4.0	1	.993	.950	.850											
5.0	1	.982	.917												
6.0	1	.968	.885												
8.0	1	.930													
10.0	.996	.880													
12.0	.985	.720													
14.0	.972														
16.0	.958														
18.0	.940														
20.0	.915														

TABLE E- Flow Rate for Shell & Tube

Shell dia . Code	Max. Liquid Flow - Shell Side					Liquid Flow - Tube Side					
	Baffle Spacing					SP		TP		FP	
	1.5	2	3	4	6	Min.	Max.	Min.	Max.	Min.	Max.
600	15	20	25	30	-	7.5	48	3.5	24	2	12
800	20	34	45	60	-	10	70	4.5	38	3	21
1000	30	36	50	65	-	20	120	10	70	5	37
1200	45	50	70	100	125	30	220	15	112	7.5	56
1700	50	65	100	140	220	57	300	29	180	14	90
2000	60	80	100	160	240	90	650	45	320	25	160

TABLE C

U	TUBE FLUID	SHELL FLUID
400	Water	Water
350	Water	50% E. Glycol
100	Water	Oil
300	50% E. Glycol	50% E. Glycol
90	50% E. Glycol	Oil

CS & STC Series performance

The selection chart provided contains an array of popular sizes for quick sizing. It does not provide curves for all models available. Refer to page 44 & 45 for detailed calculation information.

Computer selection data sheets for standard or special models are available through the engineering department of American Industrial. To use the followings graphs correctly, refer to the instruction notes "1-5".

- 1) HP Curves are based upon a 40°F approach temperature; for example: oil leaving a cooler at 125°F, using 85°F cooling water (125°F - 85°F = 40°F).
- 2) The oil to water ratio of 1:1 or 2:1 means that for every 1 gallon of oil circulated, a minimum of 1 or 1/2 gallon (respectively) of 85°F water must be circulated to match the curve results.

3) OIL PRESSURE DROP CODING: † = 5 psi; ☆ = 10 psi; ○ = 20 psi; △ = 50psi. Curves that have no pressure drop code symbols indicate that the oil pressure drop is less than 5 psi for the flow rate shown.

4) Pressure Drop is based upon oil with an average viscosity of 100 SSU. If the average oil viscosity is other than 100 SSU, then multiply the indicated Pressure Drop by the corresponding value from corrections table A.

5) Corrections for approach temperature and oil viscosity are as follows:

$$H.P. \left(\begin{smallmatrix} \text{Removed} \\ \text{In Cooler} \end{smallmatrix} \right) = H.P. \left(\begin{smallmatrix} \text{Actual} \\ \text{Heat Load} \end{smallmatrix} \right) \times \left(\frac{40}{\text{Actual Approach}} \right) \times B.$$

HEAT ENERGY DISSIPATION RATES (Basic Stock Model)

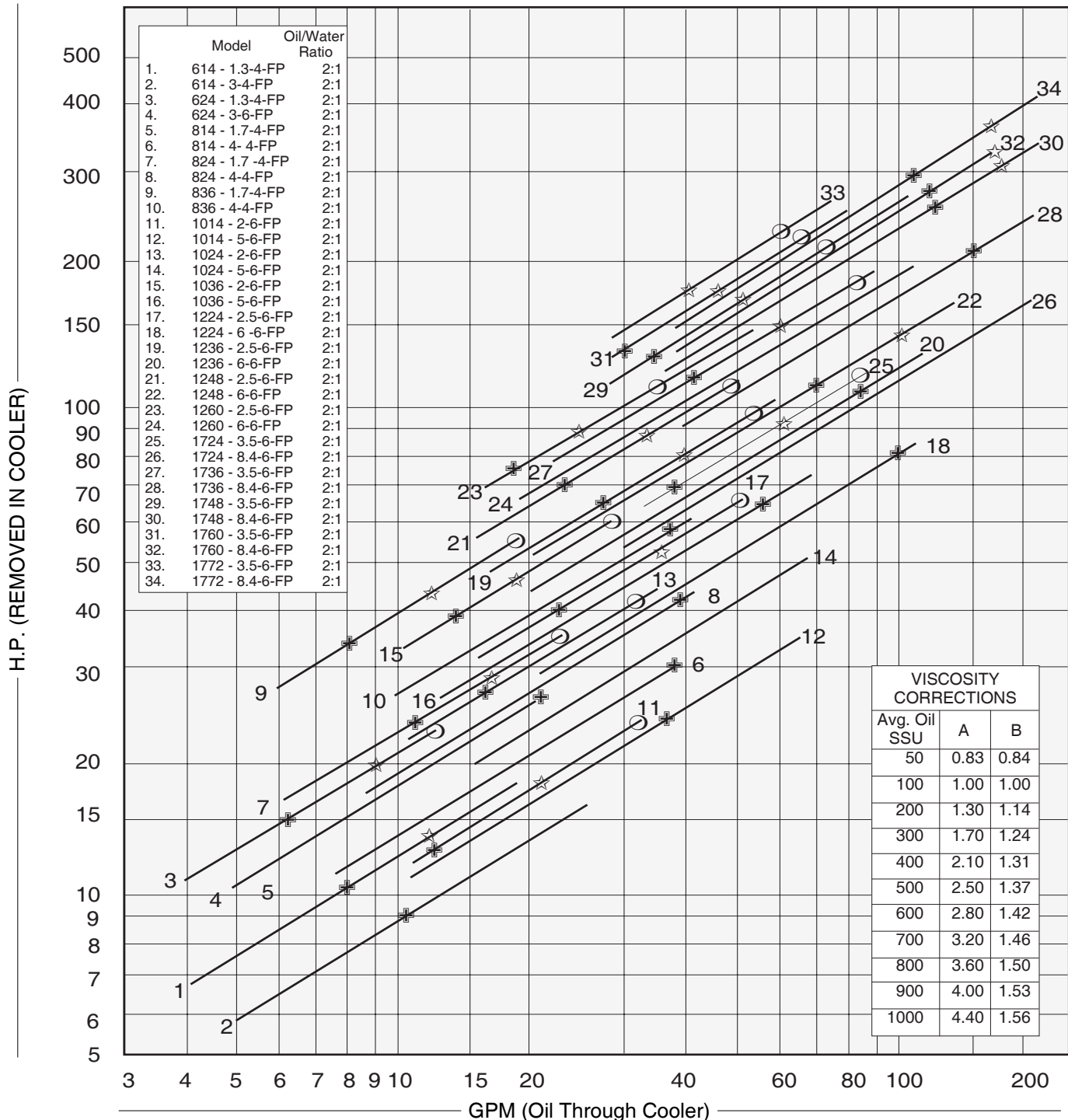

CS Series dimensions

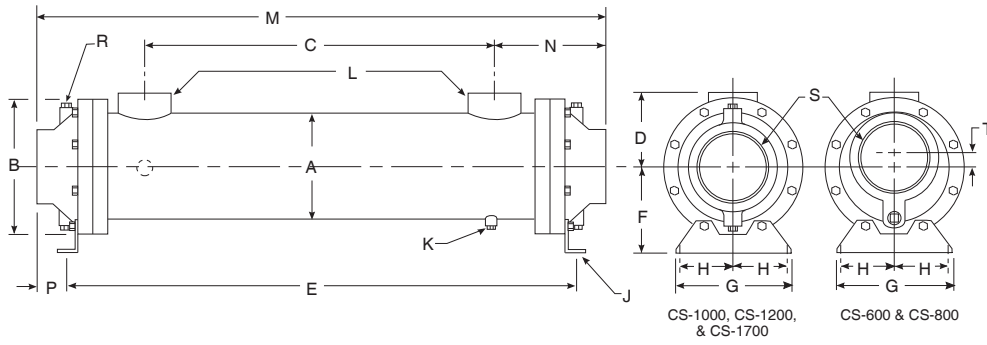

Single Pass (SP)

Model	M	N	P	R NPT	S NPT	T
CS-614	17.18	3.70	.40	(2)	1.50	.38
CS-624	27.18			.38		
CS-814	17.88					
CS-824	27.88	4.44	.63	(2)	2.00	.50
CS-836	39.88			.38		
CS-1014	19.09					
CS-1024	29.09	5.05	.92	(4)	2.00	-
CS-1036	41.09			.38		
CS-1224	30.00					
CS-1236	42.00					
CS-1248	54.00	5.88	1.43	(4)	3.00	-
CS-1260	66.00			.50		
CS-1272	78.00					
CS-1724	31.47					
CS-1736	43.47					
CS-1748	55.47	7.23	1.99	(4)	4.00	-
CS-1760	67.47			.50		
CS-1772	79.47					
CS-1784	91.47					

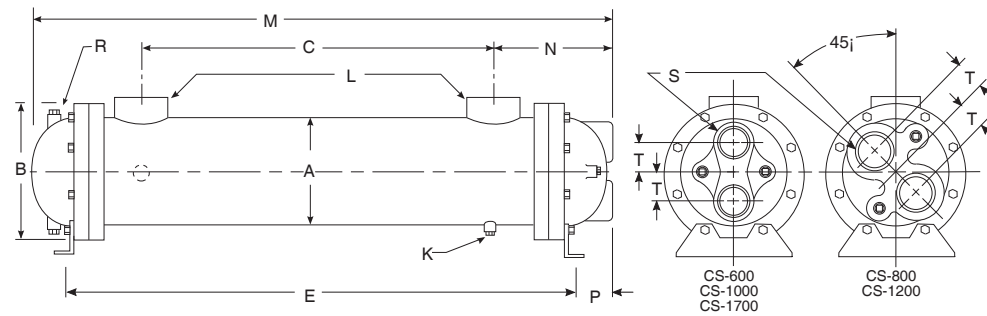

Two Pass (TP)

Model	M	N	P	R NPT	S NPT	T
CS-614	17.12	3.70	.38	(2)	1.00	1.00
CS-624	27.12			.38		
CS-814	17.88					
CS-824	27.88	4.44	.63	(2)	1.25	1.06
CS-836	39.88			.38		
CS-1014	18.62					
CS-1024	28.62	5.00	.94	(2)	1.50	1.19
CS-1036	40.62			.38		
CS-1224	29.03					
CS-1236	41.03					
CS-1248	53.03	5.44	1.00	(2)	2.00	1.44
CS-1260	65.03			.50		
CS-1272	77.03					
CS-1724	30.62					
CS-1736	42.62					
CS-1748	54.62	7.06	1.81	(2)	2.50	1.88
CS-1760	66.62			.50		
CS-1772	78.62					
CS-1784	90.62					

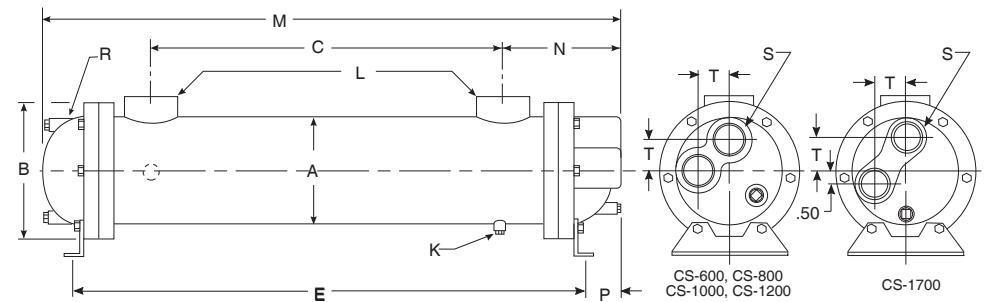

Four Pass (FP)

Model	M	N	P	R NPT	S NPT	T
CS-614	17.12	3.70	.38	(2)	.75	1.00
CS-624	27.12			.38		
CS-814	17.88					
CS-824	27.88	4.44	.63	(3)	.75	1.25
CS-836	39.88			.38		
CS-1014	18.81					
CS-1024	28.81	4.81	.75	(3)	1.00	1.69
CS-1036	40.81			.38		
CS-1224	29.13					
CS-1236	41.13					
CS-1248	53.13	5.44	1.00	(3)	1.50	2.00
CS-1260	65.13			.50		
CS-1272	77.13					
CS-1724	29.86					
CS-1736	41.86					
CS-1748	53.86	7.06	1.81	(3)	2.00	2.50
CS-1760	65.86			.50		
CS-1772	77.86					
CS-1784	89.86					

COMMON DIMENSIONS & WEIGHTS

Model	A	B	C	D	E	F	G	H	J	K NPT	L NPT	Approx. Weight	Model
CS-614			10.00		17.00					(2)		17	CS-614
CS-624	3.25	4.50	20.00	2.31	27.00	2.75	4.18	1.62	.38φx0.88	.25	1.00	24	CS-624
CS-814			9.00		16.62							32	CS-814
CS-824	4.25	6.00	19.00	3.12	26.62	3.50	4.25	1.75	.44φx1.00	(2)	1.50	41	CS-824
CS-836			31.00		38.62					.25		53	CS-836
CS-1014			9.00		17.12							43	CS-1014
CS-1024	5.25	6.75	19.00	3.62	27.12	4.00	5.25	2.00	.44φx1.00	(2)	1.50	57	CS-1024
CS-1036			31.00		39.12					.25		72	CS-1036
CS-1224			18.25		27.13							85	CS-1224
CS-1236			30.25		39.13							110	CS-1236
CS-1248	6.25	7.75	42.25	4.16	51.13	4.50	6.25	2.50	.44φx1.00	(2)	2.00	135	CS-1248
CS-1260			54.25		63.13					.38		160	CS-1260
CS-1272			66.25		75.13							185	CS-1272
CS-1724			17.00		27.50							140	CS-1724
CS-1736			29.00		39.50							180	CS-1736
CS-1748	8.13	10.12	41.00	5.62	51.50	5.75	8.25	3.50	.44φx1.00	(2)	3.00	220	CS-1748
CS-1760			53.00		63.50					.38		260	CS-1760
CS-1772			65.00		75.50							300	CS-1772
CS-1784			77.00		87.50							340	CS-1784

note: AIHTI reserves the right to make reasonable design changes without notice.

STC Series *dimensions*

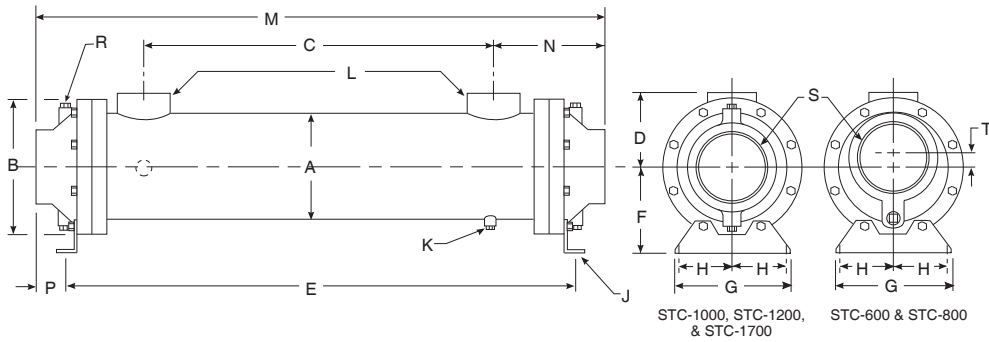

Single Pass (SP)

Model	M	N	P	R NPT	S NPT	T
STC-614	17.18	3.70	.40	(2)	1.50	.38
STC-624	27.18			.38		
STC-814	17.88					
STC-824	27.88	4.44	.63	(2)	2.00	.50
STC-836	39.88			.38		
STC-1014	19.09					
STC-1024	29.09	5.05	.92	(4)	2.00	-
STC-1036	41.09			.38		
STC-1224	30.00					
STC-1236	42.00					
STC-1248	54.00	5.88	1.43	(4)	3.00	-
STC-1260	66.00			.50		
STC-1272	78.00					
STC-1724	31.47					
STC-1736	43.47					
STC-1748	55.47	7.23	1.99	(4)	4.00	-
STC-1760	67.47			.50		
STC-1772	79.47					
STC-1784	91.47					

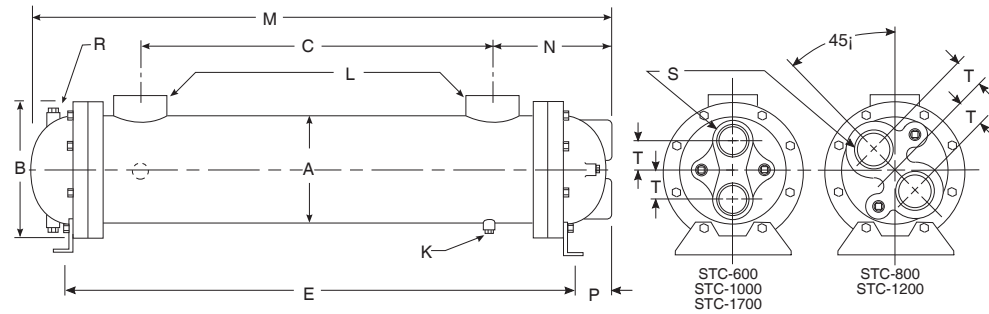

Two Pass (TP)

Model	M	N	P	R NPT	S NPT	T
STC-614	17.12	3.70	.38	(2)	1.00	1.00
STC-624	27.12			.38		
STC-814	17.88					
STC-824	27.88	4.44	.63	(2)	1.25	1.06
STC-836	39.88			.38		
STC-1014	18.62					
STC-1024	28.62	5.00	.94	(2)	1.50	1.19
STC-1036	40.62			.38		
STC-1224	29.03					
STC-1236	41.03					
STC-1248	53.03	5.44	1.00	(2)	2.00	1.44
STC-1260	65.03			.50		
STC-1272	77.03					
STC-1724	30.62					
STC-1736	42.62					
STC-1748	54.62	7.06	1.81	(2)	2.50	1.88
STC-1760	66.62			.50		
STC-1772	78.62					
STC-1784	90.62					

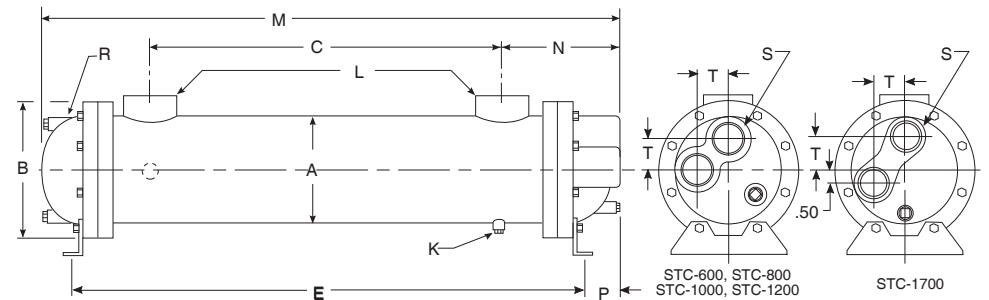

Four Pass (FP)

Model	M	N	P	R NPT	S NPT	T
STC-614	17.12	3.70	.38	(2)	.75	1.00
STC-624	27.12			.38		
STC-814	17.88					
STC-824	27.88	4.44	.63	(3)	.75	1.25
STC-836	39.88			.38		
STC-1014	18.81					
STC-1024	28.81	4.81	.75	(3)	1.00	1.69
STC-1036	40.81			.38		
STC-1224	29.13					
STC-1236	41.13					
STC-1248	53.13	5.44	1.00	(3)	1.50	2.00
STC-1260	65.13			.50		
STC-1272	77.13					
STC-1724	29.86					
STC-1736	41.86					
STC-1748	53.86	7.06	1.81	(3)	2.00	2.50
STC-1760	65.86			.50		
STC-1772	77.86					
STC-1784	89.86					

COMMON DIMENSIONS & WEIGHTS

Model	A	B	C	D	E	F	G	H	J	K NPT	L NPT	Approx. Weight	Model
STC-614			10.00		17.00					(2)		17	STC-614
STC-624	3.13	4.50	20.00	2.31	27.00	2.75	4.18	1.62	.38φx0.88	.25	1.00	24	STC-624
STC-814			9.00		16.62							32	STC-814
STC-824	4.25	6.00	19.00	3.12	26.62	3.50	4.25	1.75	.44φx1.00	(2)	1.50	41	STC-824
STC-836			31.00		38.62					.25		53	STC-836
STC-1014			9.00		17.12							43	STC-1014
STC-1024	5.25	6.75	19.00	3.62	27.12	4.00	5.25	2.00	.44φx1.00	(2)	1.50	57	STC-1024
STC-1036			31.00		39.12					.25		72	STC-1036
STC-1224			18.25		27.13							85	STC-1224
STC-1236			30.25		39.13							110	STC-1236
STC-1248	6.25	7.75	42.25	4.16	51.13	4.50	6.25	2.50	.44φx1.00	(2)	2.00	135	STC-1248
STC-1260			54.25		63.13					.38		160	STC-1260
STC-1272			66.25		75.13							185	STC-1272
STC-1724			17.00		27.50							140	STC-1724
STC-1736			29.00		39.50							180	STC-1736
STC-1748	8.00	10.12	41.00	5.62	51.50	5.75	8.25	3.50	.44φx1.00	(2)	3.00	220	STC-1748
STC-1760			53.00		63.50					.38		260	STC-1760
STC-1772			65.00		75.50							300	STC-1772
STC-1784			77.00		87.50							340	STC-1784

CS & STC Series *installation & maintenance*

PIPING HOOK-UP

A Hot fluid to be cooled
 B Cooled fluid
 C Cooling water in
 D Cooling water out

SP Single Pass
 TP Two Pass
 FP Four Pass

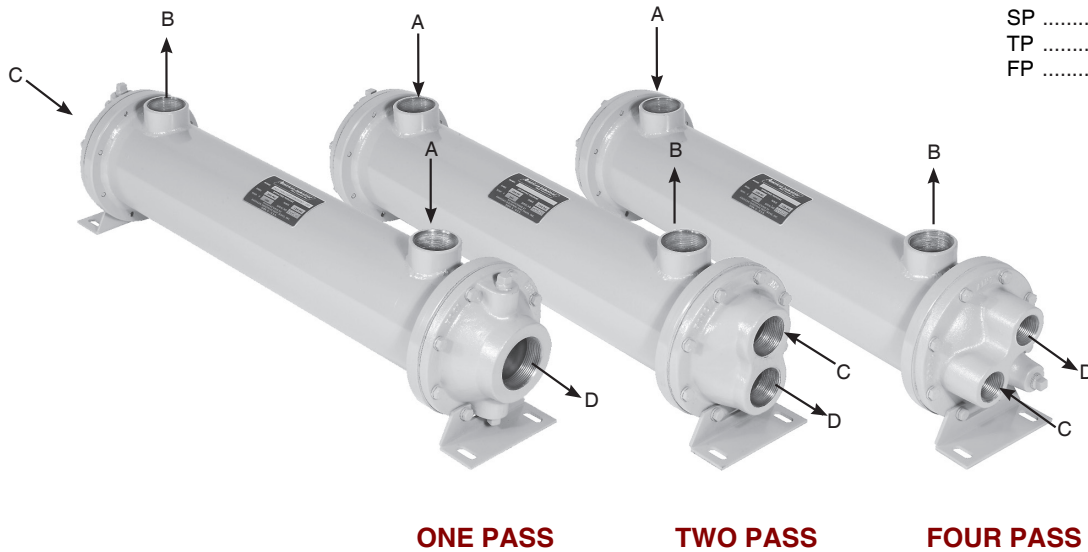

Receiving / Installation

a) Inspect unit for any shipping damage before uncrating. Indicate all damages to the trucking firms' delivery person, and mark it on the receiving bill before accepting the freight. Make sure that there is no visible damage to the outside surface of the heat exchanger. The published weight information located in this brochure is approximate. True shipment weights are determined at the time of shipping and may vary. Approximate weight information published herein is for engineering approximation purposes and should not be used for exact shipping weight. Since the warranty is based upon the unit date code located on the model identification tags, removal or manipulation of the identification tags will void the manufacturer's warranty.

b) When handling the shell & tube heat exchanger, special care should be taken to avoid dropping the unit since mishandling could cause the heat exchanger to crack and leak externally. Mishandling of the unit is not covered under the manufacturer's warranty. All units are shipped with partial wood/corrugated cardboard containers for safe handling.

c) Storage: American Industrial heat exchangers are protected against the elements during shipment. If the heat exchanger cannot be installed and put into operation immediately upon receipt, certain precautions are required to prevent deterioration during storage. The responsibility for integrity of the heat exchanger(s) is assumed by the user. American Industrial will not be responsible for damage, corrosion, or other deterioration of the heat exchanger during transit or storage.

Proper storage practices are important when considering the high costs of repair or replacement, and the possible delays for items which require long lead times for manufacture. The following listed practices are provided solely as a convenience to the user, who shall make their own decision on whether to use all or any of them.

- 1) Heat exchangers not to be placed in immediate service, require precautionary measures to prevent corrosion or contamination.
- 2) Heat exchangers made of ferrous materials, may be pressure-tested using compressed air at the factory. Residual oil coating on the inside surfaces of the heat exchanger(s) as a result of flushing does not discount the possibility of internal corrosion. Upon receipt, fill the heat exchanger(s) with the appropriate grade of oil or apply a corrosion preventing inhibitor for storage.
- 3) Corrosion protection compounds for interior surfaces for long term storage or other applications are applied solely at the request of customers. Upon request, American Industrial can provide a customer approved corrosion preventative if available when included in the

original purchase order specifications.

- 4) Remove all dirt, water, ice, or snow and wipe dry before moving heat exchanger(s) into storage. Heat exchangers are generally shipped empty, open drain plugs to remove any accumulated condensation moisture, then reseal. Accumulation of moisture usually indicates corrosion has already started and remedial action should be taken.
- 5) Store in a covered, environmentally stable area. The ideal storage environment for heat exchangers is in a dry, low-humidity atmosphere which is sealed to prevent the entry of blowing dust, rain, or snow. Maintain in atmospheric temperatures between 70°F and 105°F (Large temperature swings may cause condensation and moisture to form on steel components, threads, shell, etc...) Use thermometers and humidity indicators and maintain the atmosphere at 40% relative humidity, or lower.

d) Standard Enamel Coating: American Industrial provides its standard products with a normal base coat of oil base air cure enamel paint. The enamel paint is applied as a temporary protective and esthetic coating prior to shipment. While the standard enamel coating is durable, American Industrial does not warranty it as a long-term finish coating. It is strongly suggested that a more durable final coating be applied after installation or prior to long-term storage in a corrosive environment to cover any accidental scratches, enhance esthetics, and further prevent corrosion. It is the responsibility of the customer to provide regular maintenance against chips, scratches, etc... and regular touch up maintenance must be provided for long-term benefits and corrosion prevention.

e) Special Coatings: American Industrial offers as customer options, Air-Dry Epoxy, and Heresite (Air-Dry Phenolic) coatings at additional cost. American Industrial offers special coatings upon request, however American Industrial does not warranty coatings to be a permanent solution for any equipment against corrosion. It is the responsibility of the customer to provide regular maintenance against chips, scratches, etc... and regular touch up maintenance must be provided for long-term benefits and corrosion prevention.

f) American Industrial recommends that the equipment supplied should be installed by qualified personnel who have solid understanding of system design, pressure and temperature ratings, and piping assembly. Verify the service conditions of the system prior to applying any shell & tube heat exchanger. If the system pressure or temperature does not fall within the parameters on model rating tag located on the heat exchanger, contact our factory prior to installation or operation.

CS & STC Series *installation & maintenance*

g) Plan the installation to meet the requirements indicated on the piping installation diagram as illustrated above. It is recommended to put the hot fluid to be cooled through the shell side and the cold fluid through the tube side. The indicated port assembly sequence in the diagram maximizes the performance, and minimizes the possibility of thermal shock. In instances where the fluids are required to be reversed, *hot fluid in the tubes and cold fluid in the shell* the heat exchanger will work with reduced performance. Installation may be vertical or horizontal or a combination thereof. However, the installation must allow for complete draining of the heat exchanger regardless of Single Pass, Two Pass, or four pass construction. Complete drainage is important to prevent the heat exchanger from freezing, over-heating of a fluid, or mineral deposit buildup. For fixed bundle heat exchangers, provide sufficient clearance at one end to allow for the removal or replacement of tubes. On the opposite end, provide enough space to allow removal of the complete bonnet to provide sufficient clearance to permit tube rolling and cleaning. Allow accessible room for scheduled cleaning as needed. Include thermometer wells and pressure gauge pipe ports in piping to and from the heat exchanger located as close to the heat exchanger as possible. For more information please contact American Industrial.

h) It is recommended to use flexible hose wherever possible to reduce vibration and allow slight movement. However, hoses are not required. Hydraulic carrying lines should be sized to handle the appropriate flow and to meet system pressure drop requirements based upon the systems parameters, and not based upon the units supply and return connection size. We recommend that a low cracking pressure direct acting relief valve be installed at the heat exchanger inlet to protect it from pressure spikes by bypassing oil in the event the system experiences a high flow surge. If preventative filtration is used it should be located ahead of the cooler on both shell and tube side to catch any scale or sludge from the system before it enters the cooler. Failure to install filters ahead of the heat exchanger could lead to possible heat exchanger failure due to high pressure if the system filters plug.

i) Standard shell & tube coolers are built with a rolled tube-sheet construction. However, the differential operating temperature between the entering shell side fluid and the entering tube side fluid should not exceed 150°F. If this condition exists, a severe thermal shock could occur leading to product failure and mixing of the fluids. For applications with a differential temperatures of 150°F or more, we recommend using a series with a floating tube-sheet, u-tube, or expansion joint to reduce the potential for the effects of thermal shock.

j) Water requirements vary from location to location. If the source of cooling water is from other than a municipal water supply, it is recommended that a water strainer be installed ahead of the heat exchanger to prevent dirt and debris from entering and clogging the flow passages. If a water modulating valve is used it is recommended to be installed at the inlet to the cooler to regulate the water flow.

k) For steam service, or other related applications, please consult our engineering department for additional information.

Maintenance

a) Inspect the heat exchanger for loosened bolts, connections, rust spots, corrosion, and for internal or external fluid leakage. Any corroded surfaces should be cleaned and recoated with paint.

b) **Shell side:** In many cases with clean hydraulic system oils it will not be necessary to flush the interior of the shell side of the cooler. In circumstances where the quality of hydraulic fluid is in question, the shell side should be disconnected and flushed on a yearly basis with a clean flushing oil/solvent to remove any sludge that has been deposited. For severe cases where the unit is plugged and cannot be flushed clean with solvent, the heat exchanger should be replaced to maintain the proper cooling performance.

c) **Tube side:** In many cases it will be necessary to clean the tube side of the heat exchanger due to poor fluid quality, debris, calcium deposits, corrosion, mud, sludge, seaweed, etc.... To clean the tube side, flush with clean water or any good quality commercial cleaner that does not attack

the particular material of construction. With straight tube heat exchangers you can use a rod to carefully push any debris out of the tubes.

d) **Zinc anodes** are normally used to reduce the risk of failure due to electrolysis. Zinc anodes are a sacrificial component designed to wear and dissolve through normal use. Normally, zinc anodes are applied to the water supply side of the heat exchanger. Depending upon the amount of corrosive action, one, two, three, or more anodes can be applied to help further reduce the risk of failure. American Industrial Heat Transfer, Inc. offers zinc anodes as an option, to be specified and installed at the request of our customers. It is the responsibility of the customer to periodically check and verify the condition of the zinc anode and replace it as needed.

Applications vary due to water chemical makeup and quality, material differences, temperature, flow rate, piping arrangements, and machine grounding. For those reasons, zinc anodes do not follow any scheduled factory predetermined maintenance plan moreover they must be checked routinely by the customer, and a maintenance plan developed based upon the actual wear rate.

If substantial wear occurs or zinc dissolves without replacement, premature failure or permanent damage may occur to the heat exchanger. American Industrial does not warranty customer applications. It is the responsibility of the customer to verify and apply the proper system materials of construction and overall system requirements. Failures resulting from properly applied or misapplied use of zinc anode(s) into non-specified or specified applications will be the sole responsibility of the customer.

e) A routine maintenance schedule should be developed and adjusted to meet your systems requirements based upon water quality, etc.... Failure to regularly maintain and clean your heat exchanger can result in a reduction in operational performance and life expectancy.

Note: Since applications can vary substantially, the installation and maintenance information contained in this catalog should be used as a basic guideline. The safe installation, maintenance, and use of any American Industrial Heat Transfer, Inc. heat exchanger are solely the responsibility of the user.

