



**Shell & Tube Application Request:** *(For steam to liquid heat exchangers)*

For UCN, URCN, & UCF, URCF Series

Email form to: sales@aihti.com or engineering@aihti.com or fax to 434-757-1810

Contact Name \_\_\_\_\_ Telephone \_\_\_\_\_ Date \_\_\_\_\_

Company Name \_\_\_\_\_ Email \_\_\_\_\_

Address: \_\_\_\_\_ Fax \_\_\_\_\_

**Heated Fluid**

**Hot Side**

Fluid Type \_\_\_\_\_

Fluid Steam

If available:

Density \_\_\_\_\_ lb/ft<sup>3</sup>  
Viscosity \_\_\_\_\_ cP  
Conductivity \_\_\_\_\_ Btu/hr.ft.°F  
Specific Heat \_\_\_\_\_ Btu/lb.°F

1. Steam Pressure \_\_\_\_\_
2. Temperature In \_\_\_\_\_
3. Flow Rate of steam \_\_\_\_\_
4. Heat Load \_\_\_\_\_

1. Flow Rate \_\_\_\_\_
2. Temperature In \_\_\_\_\_
3. Temperature Out: \_\_\_\_\_
4. Maximum Allowable Pressure Drop: \_\_\_\_\_

To properly size the heat exchanger we need 3 of the 4 parameter on the Hot Side and 2 on the Cold Side.

Shell Material Construction:

Tube Material Construction:

Brass  Steel  Stainless Steel

Copper  90/10 Copper Nickel  Stainless Steel

ASME Code and Certified Yes  No

Require All Stainless Steel Heat Exchanger Yes  No

Comment: \_\_\_\_\_  
\_\_\_\_\_  
\_\_\_\_\_

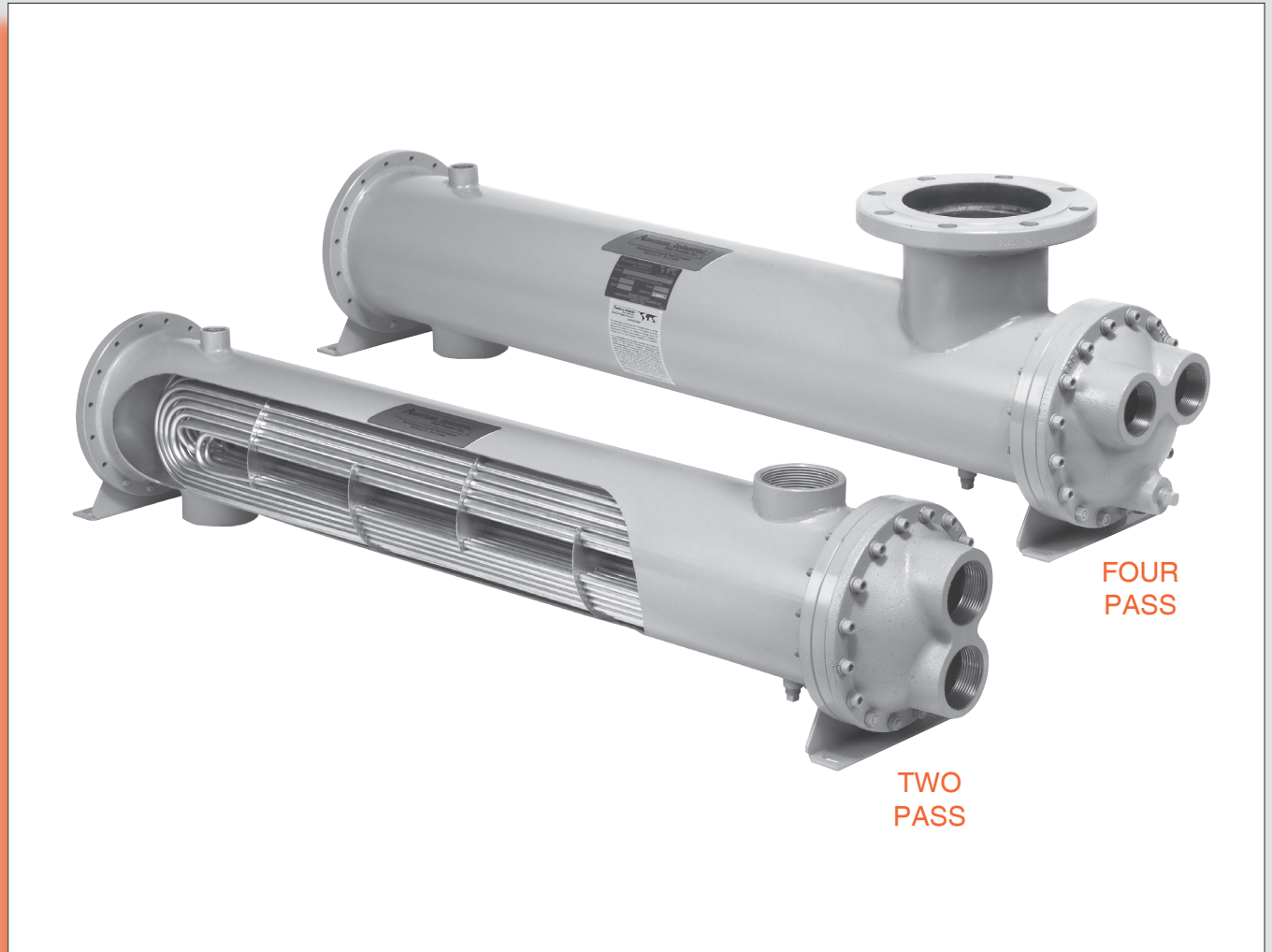
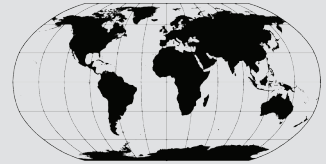

## U-TUBE FIXED & REMOVEABLE BUNDLE

# HEAT EXCHANGERS

*For steam to liquid service*

- Operating pressure for tubes 100 PSI.
- Operating pressure for shell 100 PSI.
- Operating temperature 400 °F.
- Can be customized to fit any application.
- Computer generated data sheet available for any application
- As an option, available in ASME Code and Certified

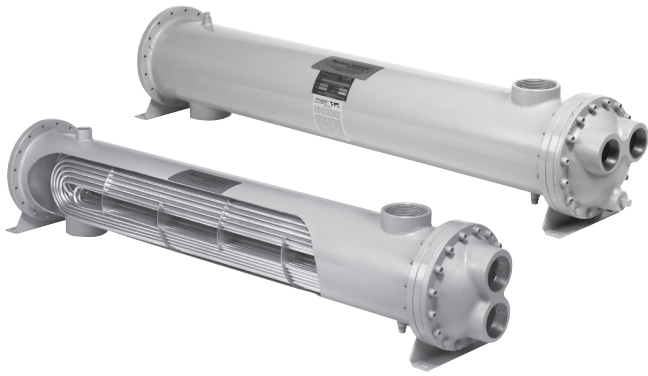

## **UCN, URCN SERIES**

U-tube heat exchangers with fixed or removeable tube bundle for steam service. Normally applied when the differential temperature between the hot fluid entering and the cooling fluid entering is 150°F or greater. U-tube design allows tubing to freely expand and contract independently of the shell. Welded outer shell construction made of carbon steel with NPT connection ports. Sizes from 5" to 10" diameters. Standard two and four pass units available. Optional 90/10 copper nickel, stainless steel, and carbon steel tube. Can be modified to meet your requirements.



## **UCF & URCF SERIES**

U-tube heat exchangers with fixed or removeable tube bundle for steam service. Normally applied when the differential temperature between the hot fluid entering and the cooling fluid entering is 150°F or greater. U-tube design allows tubing to freely expand and contract independently of the shell. Welded outer shell construction made of carbon steel with ANSI flange ports. Sizes from 5" to 10" diameters. Standard two and four pass units available. Optional 90/10 copper nickel, stainless steel, and carbon steel tube. Can be modified to meet your requirements.



## **STANDARD URCS STOCK UNIT FOR STEAM APPLICATION**

U-tube heat exchangers with removeable tube bundle for fluids with high differential inlet temperatures or where tube bundle requires removal. Normally applied when the differential temperature between the hot fluid entering and the cooling fluid entering is 150°F or greater. U-tube design allows tubing to freely expand and contract independently of the shell. Welded outer shell construction made of carbon steel with NPT or ANSI flange ports and viton o-ring seals. Sizes from 4" to 8" diameters. Standard two pass units available. Can be modified to meet your requirements. See page 140 for detailed dimension.



## **ACW / AOCHW SERIES**

*Can be use as a Space heater by using steam or hot water*

# UCN, URCN, UCF & URCF Series *construction*

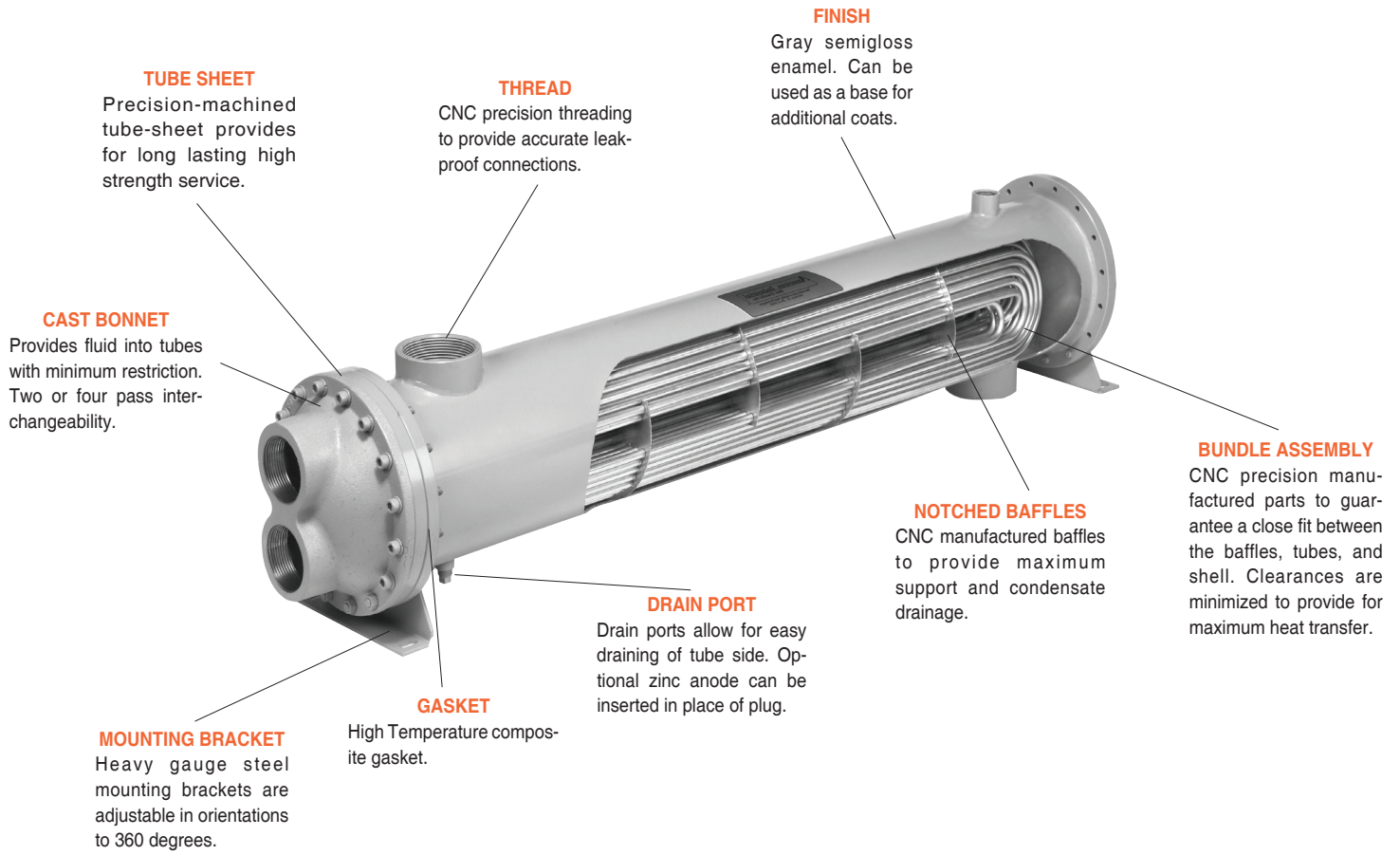

## UNIT CODING

### Example Model

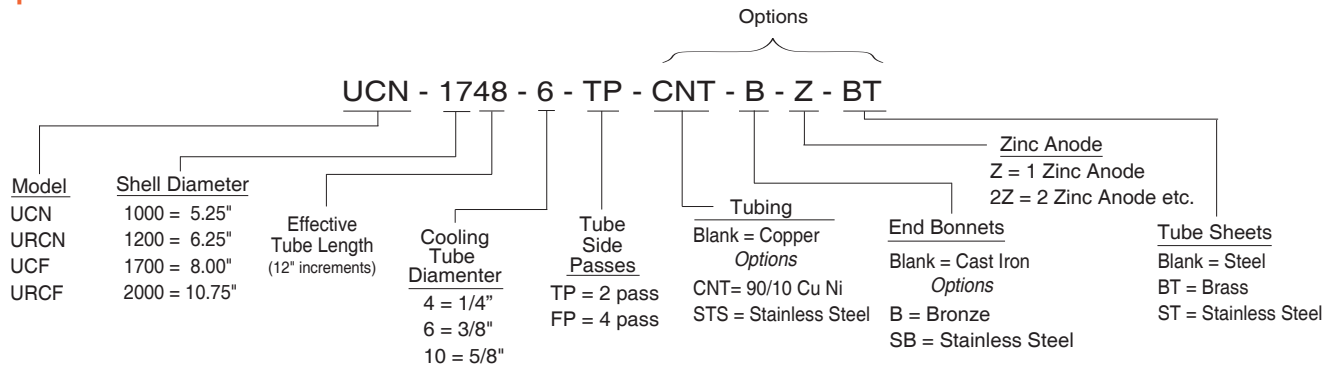

## STANDARD CONSTRUCTION MATERIALS & RATINGS

Standard Model	UCN / URCN & UCF / URCF	Options	Standard Unit Ratings
Shell	Steel	Stainless Steel	Operating Pressure Tubes 100 psig Operating Pressure Shell 100 psig Operating Temperature 400 °F
Tubes	Copper	90/10 Cu. Ni. / Stainless Steel	
Baffles	Aluminum / Brass	Stainless Steel	
Tube Sheet	Steel	Brass / Stainless Steel	
End Bonnets	Cast Iron	Stainless Steel	
Mounting Brackets	Steel	Stainless Steel	
Gasket	High Temperature Gasket	Viton	

note: AIHTI reserves the right to make reasonable design changes without notice.

# UCN, URCN, UCF & URCF Series selection

## Example [A] Calculate surface area required.

Heat 50gpm fresh water from 70°F to 170°F, using saturated steam at 50psig.

$T_s$  = Steam temperature °F  
 $t_{in}$  = Cold Side entering fluid °F  
 $t_{out}$  = Cold Side exiting fluid °F

### Step 1. Calculate the heat load Btu/hr [Q].

$Q = \text{GPM} \times \text{CN} \times \Delta T$   
 $Q = 50\text{gpm} \times 500 \times (170^\circ\text{F} - 70^\circ\text{F}) = 2,500,000 \text{ Btu/hr}$

### Step 2 Acquire steam temperature and enthalpy from graphs T&L

50psig = 297°F steam. From graph **T** (pg. 110).  
 50psig = 912 Btu/lb. From graph **L** (pg. 111).

### Step 3. Calculate the mean temperature difference (MTD)

$$\frac{T_s - t_{in}}{T_s - t_{out}} = \frac{297^\circ\text{F} - 70^\circ\text{F}}{297^\circ\text{F} - 170^\circ\text{F}} = \frac{227^\circ\text{F (Larger) L}}{127^\circ\text{F (Smaller) S}}$$

$$\frac{S}{L} = \frac{127^\circ\text{F}}{227^\circ\text{F}} = .559 \text{ Go to Table A } .559 = .758$$

Find the LMTD = [.758 x (L) 227] = 172.0

### Step 4. Calculate the surface area required.

$$A_s = \frac{Q \text{ (Btu/hr)}}{\text{LMTD} \times U} = \frac{2,500,000}{172 \times 300} = 48.4 \text{ sq. ft.}$$

### Step 5. Calculate the Capacity Factor [F<sub>c</sub>] for steam.

$$F_c = \frac{Q}{\text{Btu/lb}} = \frac{2,500,000 \text{ Btu/hr}}{912 \text{ Btu/lb}} = 2,741.3 \text{ lbs/hr steam}$$

### Step 6. Select a the proper diameter heat exchanger using graphs F or G and F<sub>c</sub> from step 5.

Capacity = 2741.3 @ 50psig = 1700 series 3/8 or 5/8 tubes from chart (G).

Use table **D** to determine the final heat exchanger size.  
 48.4 sq.ft. = **URCF-1748-6-TP**

### Application [B] Calculate using the graphs.

Heat 70gpm fresh water from 50°F to 180°F using 65psig saturated steam.

### Step 1. Calculate the heat load Btu/hr [Q].

$Q = \text{GPM} \times \text{CN} \times \Delta T$   
 $Q = 70 \times 500 \times (180^\circ\text{F} - 50^\circ\text{F}) = 4,550,000 \text{ Btu/hr}$

### Step 2. Derive the steam temperature [T<sub>s</sub>] from the graph T. Derive the capacity factor [F<sub>c</sub>] from graph L.

65psig = 312°F steam. From graph **T**  
 65psig = 901 Btu/lb. From graph **L**

### Step 3. Calculate the F<sub>s</sub> required.

$$F_s = \frac{\text{Btu/hr [Q]}}{T_s - t_{out}} = \frac{4,550,000}{312^\circ\text{F} - 180^\circ\text{F}} = 34,470$$

### Step 4. Calculate the Capacity Factor F<sub>c</sub> for steam.

$$F_c = \frac{Q}{\text{Btu/lb}} = \text{lbs/hr} \frac{2,500,000 \text{ Btu/hr}}{912 \text{ Btu/lb}} = 5,050 \text{ lbs/hr steam required}$$

### Step 5. Select the proper diameter heat exchanger using the capacity graphs F or G and F<sub>c</sub> from step 4.

Capacity = 5050 = 2000 series with 5/8" Tubes.

### Step 6. Select the proper size heat exchanger from the performance curves corresponding to the series selected using the capacity factor. Select the heat exchanger closest to the line landing on or above the calculated point.

$F_s = 34,470 \text{ Btu/hr f} = \text{URCF } 2084\text{-}6\text{-TP}$

### Application [C] Calculate batch heating of a tank.

Heat a 1000 gallon stainless steel tank of water from 50°F to 150°F in 1.5 hours using 40psig saturated steam, circulating at 30gpm. Tank size 6ft w x 6ft h x 6ft d. Ambient air temperature 60°F worse case.

### Step 1. Calculate the total heat load [Q] Btu/hr.

$Q = \text{Total Gallons} \times \text{lbs/gallon} \times \text{Specific heat Btu/lb} \times \Delta T$   
 $Q = 1000 \times 8.34 \times 1.0 \times 100^\circ\text{F} = 834,000 \text{ Btu}$

$$\text{Corrected } Q \text{ for time} = \frac{834,000 \times 60 \text{ min}}{(1.5\text{hours}) \times 60 \text{ min}} = 556,000 \text{ Btu/hr}$$

### Step 2. Calculate the $\Delta T_{\text{average}}$ (T<sub>a</sub>) for the heated water.

$$\Delta T_a = \frac{T_f - T_i}{2} + T_i \quad T_a = \frac{150^\circ\text{F} - 50^\circ\text{F}}{1.5 \text{ hours}} + 50^\circ\text{F} = 116.7^\circ\text{F}$$

$Q_{\text{Loss}} = \text{Surface area tank sq.ft} \times .001 \times \Delta t_a \times 2545$   
 $Q_{\text{Loss}} = 6 \times 6 \times 6 \times .001 \times (116.7^\circ\text{F}_a - 60^\circ\text{F}) \times 2545 = 31,169 \text{ Btu/hr}$

$$Q_t = Q + Q_{\text{Loss}} = Q_t \quad 556,000 + 31,169 = 587,169 \text{ Btu/hr}$$

### Step 3. Derive the steam temperature [T<sub>s</sub>] from graph T. Derive the capacity factor from graph L.

Given 40psig saturated steam = 287°F steam acquired from graph **T**.  
 Given 40psig saturated steam = 920 Btu/lb acquired from graph **L**.

### Step 4. Calculate the mean temperature difference (MTD)

$$\frac{T_s - T_a}{T_s - T_c} = \frac{287^\circ\text{F} - 100^\circ\text{F}}{287^\circ\text{F} - 150^\circ\text{F}} = \frac{187^\circ\text{F}}{137^\circ\text{F}}$$

$$\frac{S}{L} = \frac{137^\circ\text{F}}{187^\circ\text{F}} = .732 \text{ Goto Table A. } .732 = .659$$

Calculate the Log mean temperature difference LMTD

$$\text{LMTD} = [.659 \times (L) 187^\circ\text{F}] = 123.2$$

### Step 5. Calculate the required surface area.

$$A_s = \frac{Q}{\text{LMTD} \times U} = \frac{587,169 \text{ Btu/hr}}{123.2 \times 300} = 15.9 \text{ sq. ft.}$$



# UCN, URCN, UCF & URCF Series selection

Step 6. Select the proper diameter heat exchanger by calculating the capacity factor.

$$F_c = \frac{Q}{\text{Btu/lb}} = \text{lbs/hr} \quad \frac{587,169 \text{ Btu/hr}}{920 \text{ Btu/lb}} = 639 \text{ lbs/hr}$$

From graph F or G select the proper diameter heat exchanger.  
Capacity 639 lbs/hr saturated steam required @ 40psig.

Capacity = 639 lbs/hr = 1000 series 3/8" tubes

Step 7. Select the proper size heat exchanger from the surface area chart in table D.

Minimum surface area required = 15.9 sq.ft. = URCN1036-6-TP

Step 8. Select same using the performance chart.

$$F_s = \frac{\text{Btu/hr}}{T_s - T_{\text{exit}}} = \frac{587,169}{287 - 150} = 4,286 F_s$$

From the chart 1000, 3/8" tubes on page ( ) select unit landing closest on or above intersection point of 30gpm & 4,286 Btu/hr °F

Selection = URCN1036-6-TP

**TABLE A- FACTOR M/LMTD = L x M**

S/L	M	S/L	M	S/L	M	S/L	M
.01	.215	.25	.541	.50	.721	.75	.870
.02	.251	.26	.549	.51	.728	.76	.874
.03	.277	.28	.556	.52	.734	.77	.879
.04	.298	.29	.574	.54	.746	.79	.890
.05	.317	.30	.582	.55	.753	.80	.896
.06	.334	.31	.589	.56	.759	.81	.902
.07	.350	.32	.597	.57	.765	.82	.907
.08	.364	.33	.604	.58	.771	.83	.913
.09	.378	.34	.612	.59	.777	.84	.918
.10	.391	.35	.619	.60	.783	.85	.923
.11	.403	.36	.626	.61	.789	.86	.928
.12	.415	.37	.634	.62	.795	.87	.934
.13	.427	.38	.641	.63	.801	.88	.939
.14	.438	.39	.648	.64	.806	.89	.944
.15	.448	.40	.655	.65	.813	.90	.949
.16	.458	.41	.662	.66	.818	.91	.955
.17	.469	.42	.669	.67	.823	.92	.959
.18	.478	.43	.675	.68	.829	.93	.964
.19	.488	.44	.682	.69	.836	.94	.970
.20	.497	.45	.689	.70	.840	.95	.975
.21	.506	.46	.695	.71	.848	.96	.979
.22	.515	.47	.702	.72	.852	.97	.986
.23	.524	.48	.709	.73	.858	.98	.991
.24	.533	.49	.715	.74	.864	.99	.995

**TABLE D- Surface Area**

Model Number	Surface Area in Sq.ft.		Model Number	Surface Area in Sq.ft.	
	3/8" O.D Tubing CODE 6	5/8" O.D Tubing CODE 10		3/8" O.D Tubing CODE 6	5/8" O.D Tubing CODE 10
1024	11.0	6.5	1724	32.2	17.0
1036	16.5	9.8	1736	48.3	25.5
1048	22.0	13.0	1748	64.4	34.0
			1760	80.5	42.5
1224	17.3	9.1	1772	96.6	51.0
1236	25.9	13.7	1784	112.7	59.5
1248	34.5	18.3			
1260	43.2	22.9	2036	80.1	41.2
1272	51.8	27.5	2048	106.8	55.0
1284	60.5	32.0	2060	133.5	68.7
			2072	160.2	82.5
			2084	186.9	96.2

**TABLE E- Flow Rate for Shell & Tube**

Shell dia. Code	Liquid Flow - Tube Side							
	3/8" TP		5/8" TP		3/8" FP		5/8" FP	
	Min.	Max.	Min.	Max.	Min.	Max.	Min.	Max.
1000	5	60	5	60	5	37	5	33
1200	5	100	5	100	7.5	56	7.5	50
1700	10	180	10	160	14	90	14	80
2000	15	340	15	300	25	160	25	145

**GRAPH F**

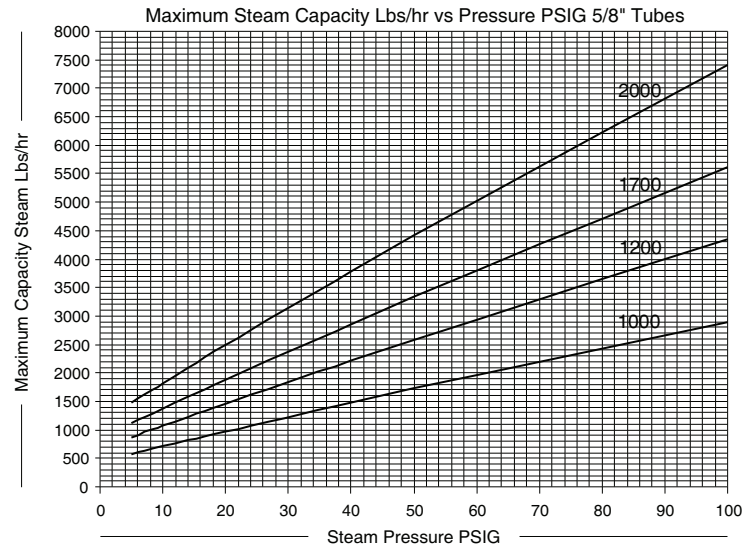
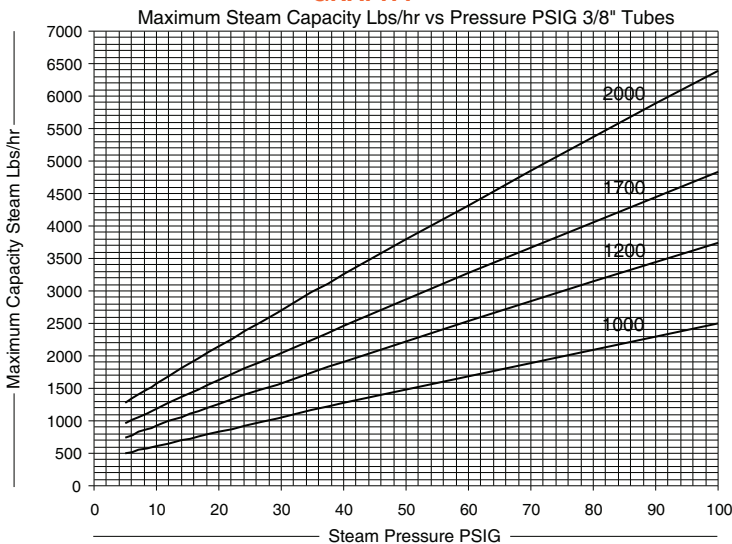

note: AIHTI reserves the right to make reasonable design changes without notice.

# UCN, URCN, UCF & URCF Series selection

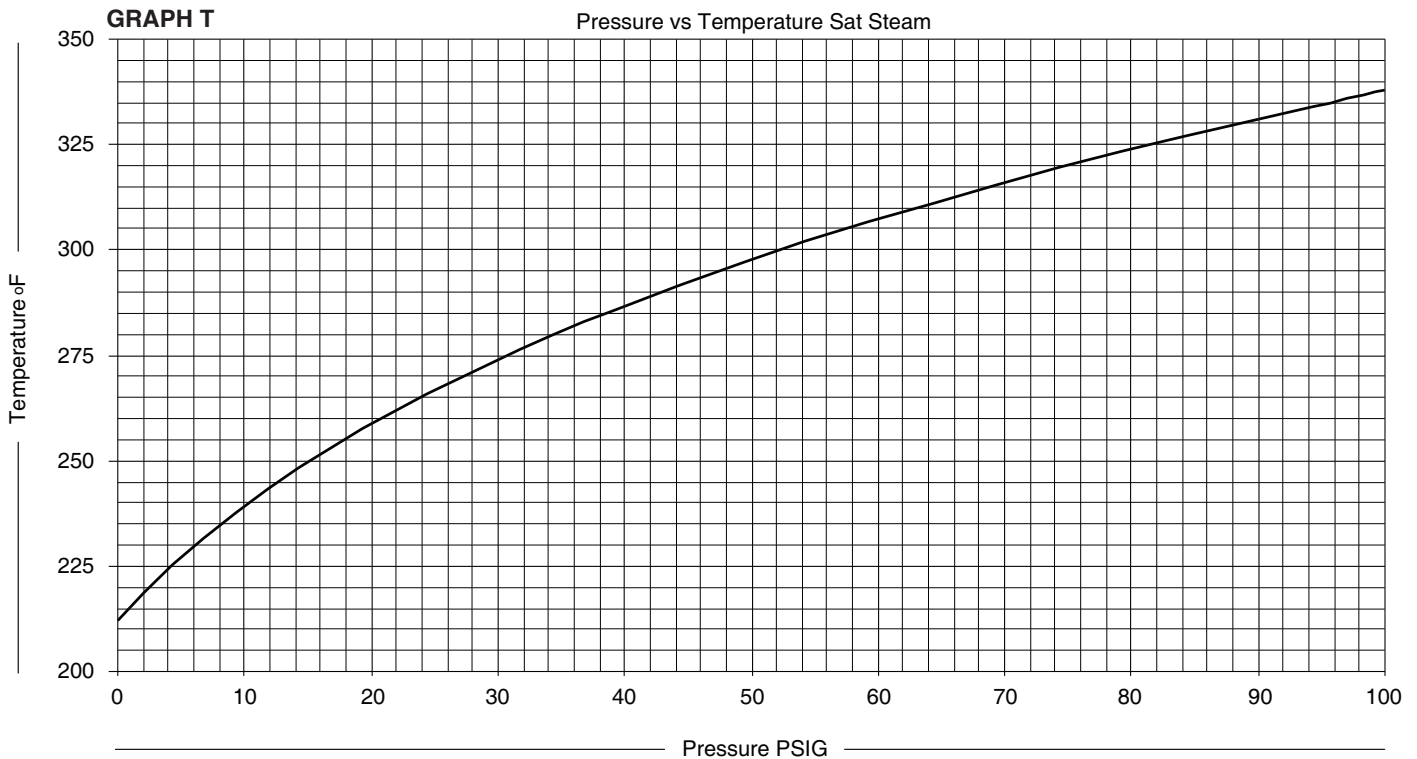
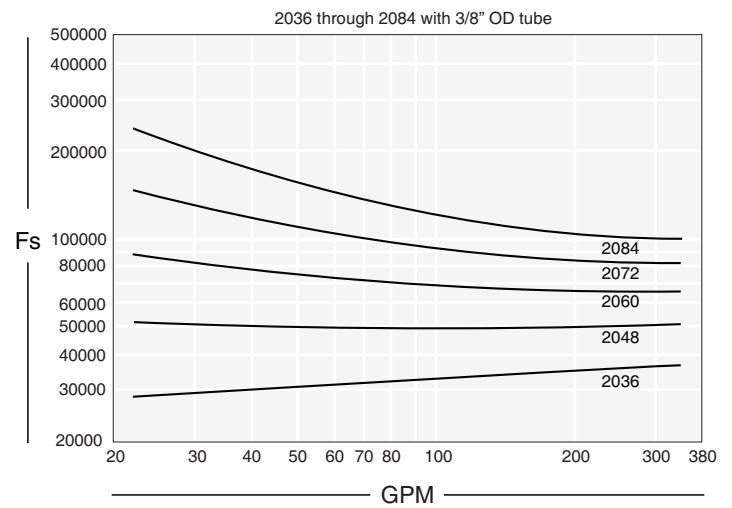
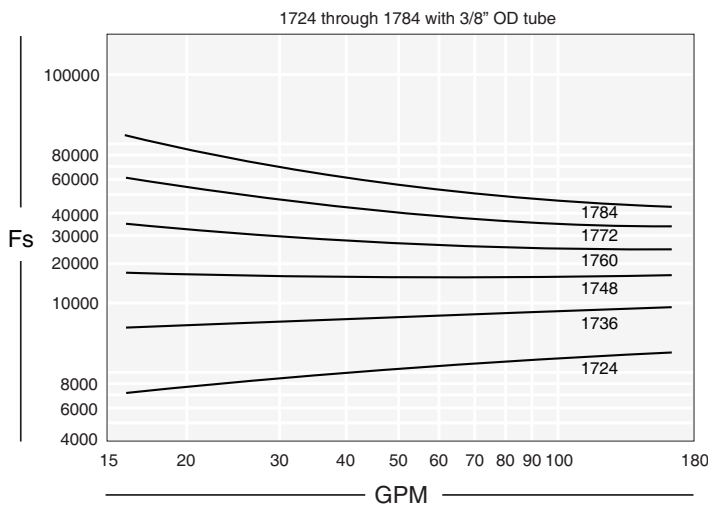
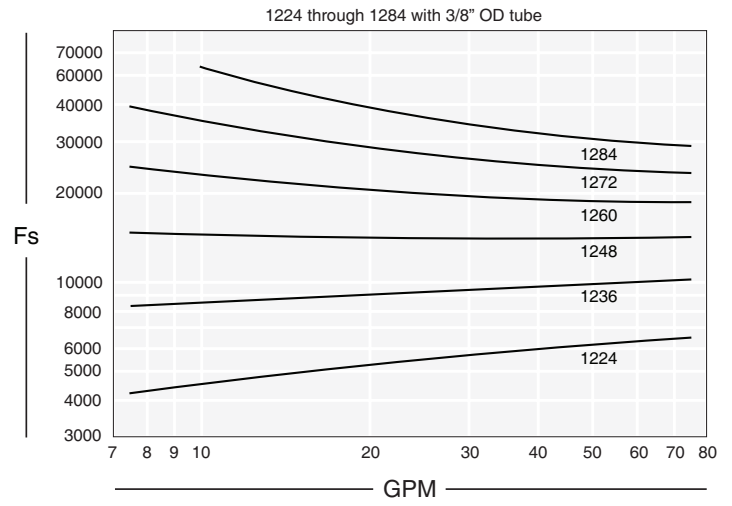
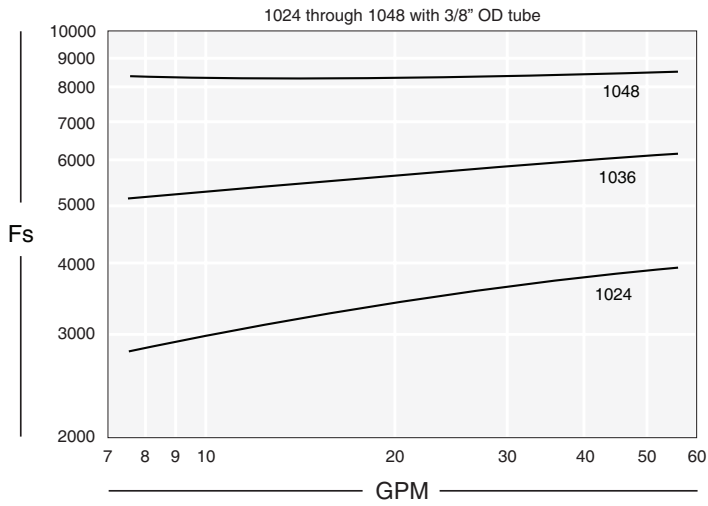

# UCN, URCN, UCF & URCF Series *selection*

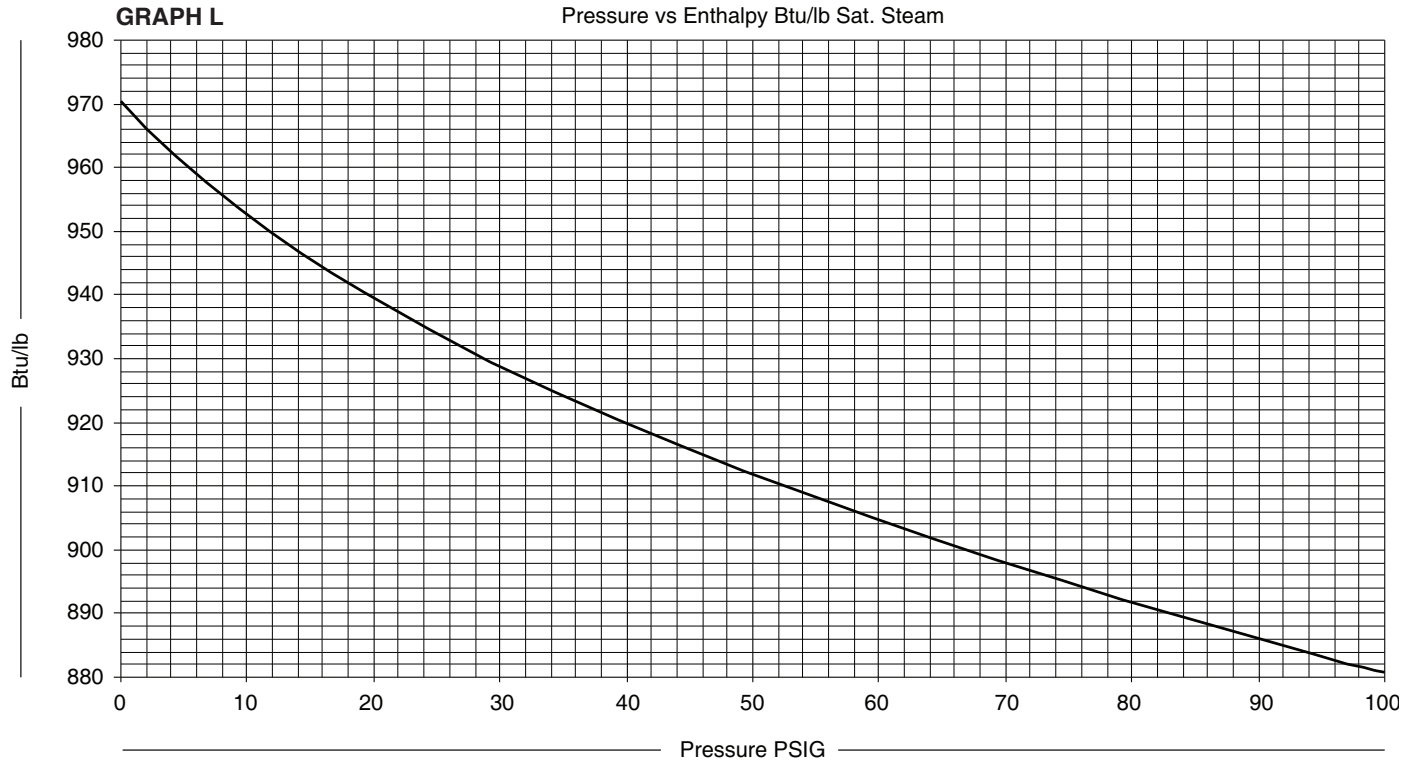
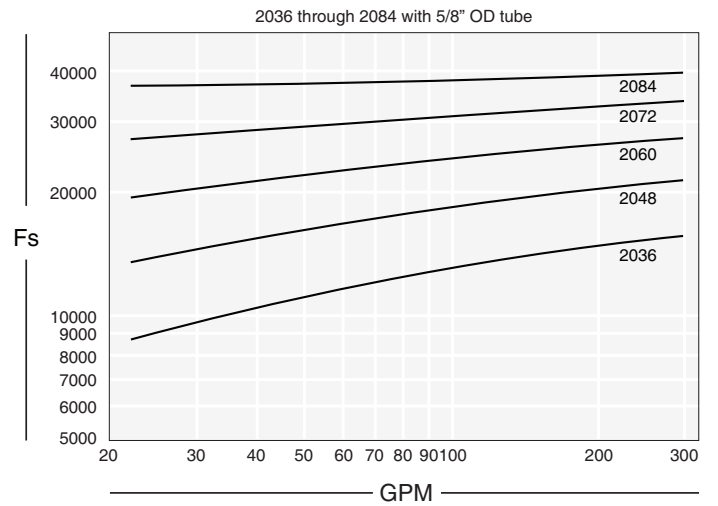
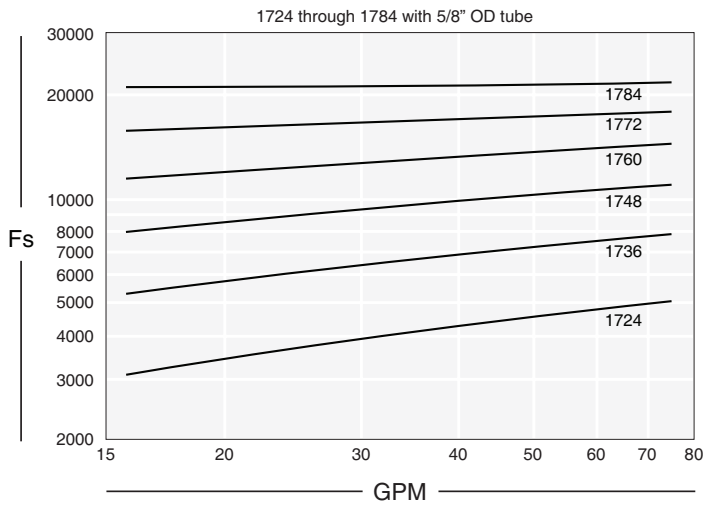
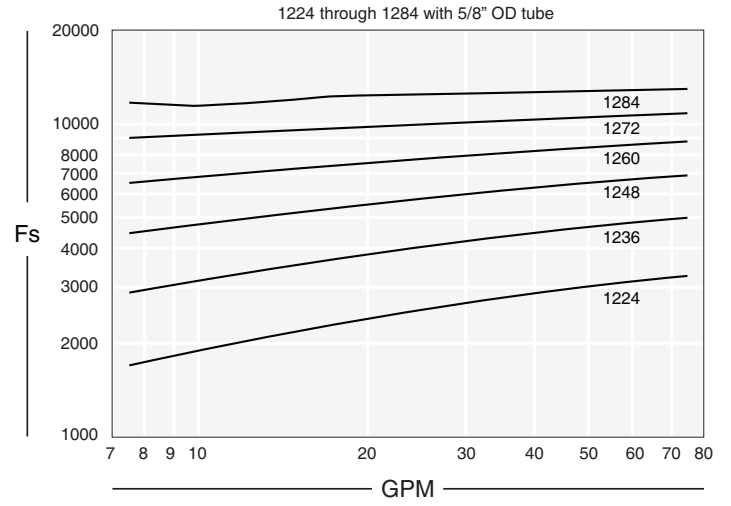
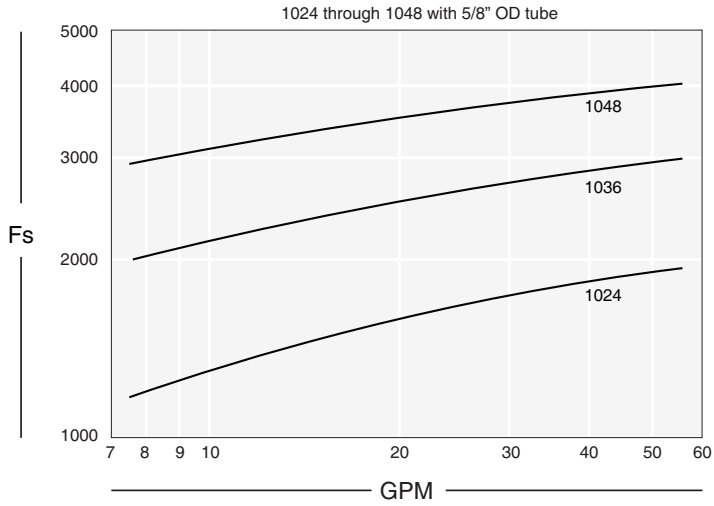

note: AIHTI reserves the right to make reasonable design changes without notice.



# UCN Series

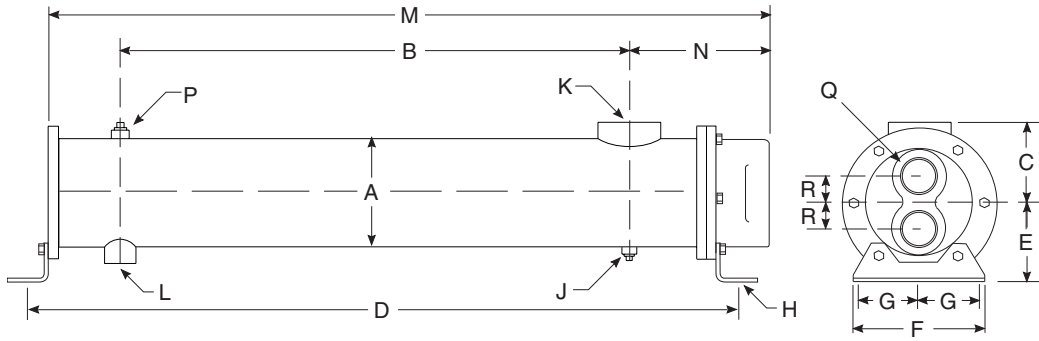

**TWO PASS (TP)**

Model	M	N	Q NPT	R
UCN-1024	28.88			
UCN-1036	40.88	6.00	1.50	1.19
UCN-1048	52.88			
UCN-1224	29.17			
UCN-1236	41.17	6.67	2.00	1.44
UCN-1248	53.17			
UCN-1260	65.17			
UCN-1272	77.17			
UCN-1284	89.17			
UCN-1724	30.13			
UCN-1736	42.13	7.88	2.50	1.88
UCN-1748	54.13			
UCN-1760	66.13			
UCN-1772	78.13			
UCN-1784	90.13			
UCN-2036	43.91			
UCN-2048	55.91	10.16	3.00	2.50
UCN-2060	67.91			
UCN-2072	79.91			
UCN-2084	91.91			

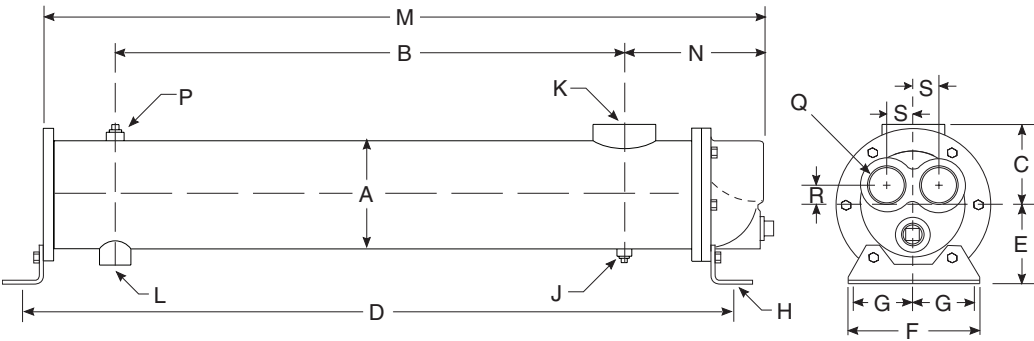

**FOUR PASS (FP)**

Model	M	N	Q NPT	R	S
UCN-1024	29.21				
UCN-1036	41.21	6.34	1.00	.75	1.19
UCN-1048	53.21				
UCN-1224	29.58				
UCN-1236	41.58	7.08	1.50	1.06	1.44
UCN-1248	53.58				
UCN-1260	65.58				
UCN-1272	77.58				
UCN-1284	84.58				
UCN-1724	29.78				
UCN-1736	41.78	7.53	2.00	1.38	1.88
UCN-1748	53.78				
UCN-1760	65.78				
UCN-1772	77.78				
UCN-1784	89.78				
UCN-2036	44.00				
UCN-2048	56.00	10.26	2.50	1.75	2.50
UCN-2060	68.00				
UCN-2072	80.00				
UCN-2084	92.00				

## COMMON DIMENSIONS

Model	A	B	C	D	E	F	G	H	J NPT	K NPT	L NPT	P NPT	Weight	Model
UCN-1024				29.13									55.00	UCN-1024
UCN-1036	5.25	32.00	3.69	41.13	4.00	5.25	2.00	.44 x 1.00 thru slot	.375	2.00	1.50	.75	70.00	UCN-1036
UCN-1048		44.00		53.13									85.00	UCN-1048
UCN-1224		19.00		29.59									83.00	UCN-1224
UCN-1236		31.00		41.59									108.00	UCN-1236
UCN-1248	6.25	43.00	4.19	53.59	4.50	6.25	2.50	.44 x 1.00 thru slot	.375	2.50	2.00	.75	132.00	UCN-1248
UCN-1260		55.00		65.59									158.00	UCN-1260
UCN-1272		67.00		77.59									182.00	UCN-1272
UCN-1284		79.00		89.59									206.00	UCN-1284
UCN-1724		19.00		29.50									138.00	UCN-1724
UCN-1736		31.00		41.50									180.00	UCN-1736
UCN-1748	8.00	43.00	5.06	53.50	5.75	8.25	3.50	.44 x 1.00 thru slot	.375	3.00	2.00	1.00	219.00	UCN-1748
UCN-1760		55.00		65.50									258.00	UCN-1760
UCN-1772		67.00		77.50									300.00	UCN-1772
UCN-1784		79.00		89.50									342.00	UCN-1784
UCN-2036		30.00		42.63									620.00	UCN-2036
UCN-2048		42.00		54.63									670.00	UCN-2048
UCN-2060	10.75	54.00	6.88	66.63	8.00	11.50	5.00	.781 x 1.25 thru slot	.50	4.00	3.00	1.25	730.00	UCN-2060
UCN-2072		66.00		78.63									820.00	UCN-2072
UCN-2084		78.00		90.63									870.00	UCN-2084

note: AIHTI reserves the right to make reasonable design changes without notice.

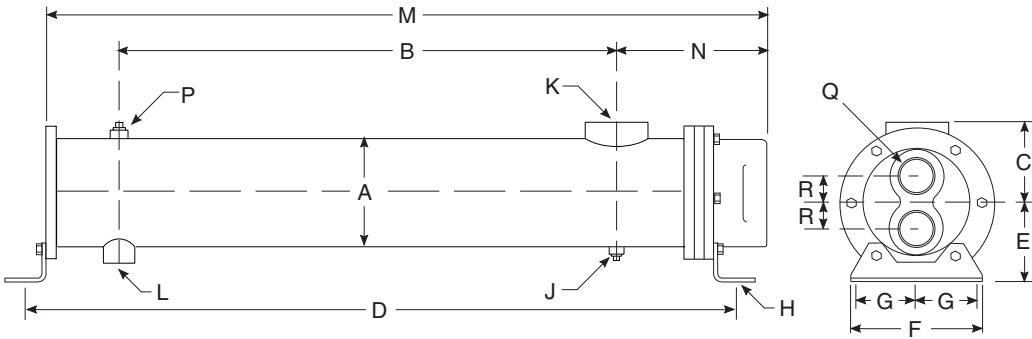

### TWO PASS (TP)

Model	M	N	Q NPT	R
URCN-1024	28.88			
URCN-1036	40.88	6.00	1.50	1.19
URCN-1048	52.88			
URCN-1224	29.17			
URCN-1236	41.17			
URCN-1248	53.17	6.67	2.00	1.44
URCN-1260	65.17			
URCN-1272	77.17			
URCN-1284	89.17			
URCN-1724	30.13			
URCN-1736	42.13			
URCN-1748	54.13	7.88	2.50	1.88
URCN-1760	66.13			
URCN-1772	78.13			
URCN-1784	90.13			
URCN-2036	43.91			
URCN-2048	55.91			
URCN-2060	67.91	10.16	3.00	2.50
URCN-2072	79.91			
URCN-2084	91.91			

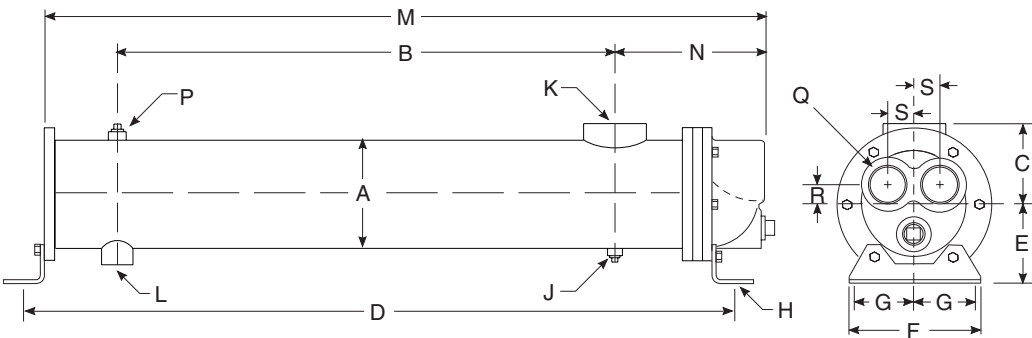

### FOUR PASS (FP)

Model	M	N	Q NPT	R	S
URCN-1024	29.21				
URCN-1036	41.21	6.34	1.00	.75	1.19
URCN-1048	53.21				
URCN-1224	29.58				
URCN-1236	41.58				
URCN-1248	53.58	7.08	1.50	1.06	1.44
URCN-1260	65.58				
URCN-1272	77.58				
URCN-1284	84.58				
URCN-1724	29.78				
URCN-1736	41.78				
URCN-1748	53.78	7.53	2.00	1.38	1.88
URCN-1760	65.78				
URCN-1772	77.78				
URCN-1784	89.78				
URCN-2036	44.00				
URCN-2048	56.00				
URCN-2060	68.00	10.26	2.50	1.75	2.50
URCN-2072	80.00				
URCN-2084	92.00				

## COMMON DIMENSIONS

Model	A	B	C	D	E	F	G	H	J NPT	K NPT	L NPT	P NPT	Weight	Model
URCN-1024		20.00		29.13									55.00	URCN-1024
URCN-1036	5.25	32.00	3.69	41.13	4.00	5.25	2.00	.44 x 1.00 thru slot	.375	2.00	1.50	.75	70.00	URCN-1036
URCN-1048		44.00		53.13									85.00	URCN-1048
URCN-1224		19.00		29.59									83.00	URCN-1224
URCN-1236		31.00		41.59									108.00	URCN-1236
URCN-1248	6.25	43.00	4.19	53.59	4.50	6.25	2.50	.44 x 1.00 thru slot	.375	2.50	2.00	.75	132.00	URCN-1248
URCN-1260		55.00		65.59									158.00	URCN-1260
URCN-1272		67.00		77.59									182.00	URCN-1272
URCN-1284		79.00		89.59									206.00	URCN-1284
URCN-1724		19.00		29.50									138.00	URCN-1724
URCN-1736		31.00		41.50									180.00	URCN-1736
URCN-1748	8.00	43.00	5.06	53.50	5.75	8.25	3.50	.44 x 1.00 thru slot	.375	3.00	2.00	1.00	219.00	URCN-1748
URCN-1760		55.00		65.50									258.00	URCN-1760
URCN-1772		67.00		77.50									300.00	URCN-1772
URCN-1784		79.00		89.50									342.00	URCN-1784
URCN-2036		30.00		42.63									620.00	URCN-2036
URCN-2048		42.00		54.63									670.00	URCN-2048
URCN-2060	10.75	54.00	6.88	66.63	8.00	11.50	5.00	.781 x 1.25 thru slot	.50	4.00	3.00	1.25	730.00	URCN-2060
URCN-2072		66.00		78.63									820.00	URCN-2072
URCN-2084		78.00		90.63									870.00	URCN-2084

note: AIHTI reserves the right to make reasonable design changes without notice.

# UCF Series dimensions

## FIXED TUBE BUNDLE (U-TUBE DESIGN)

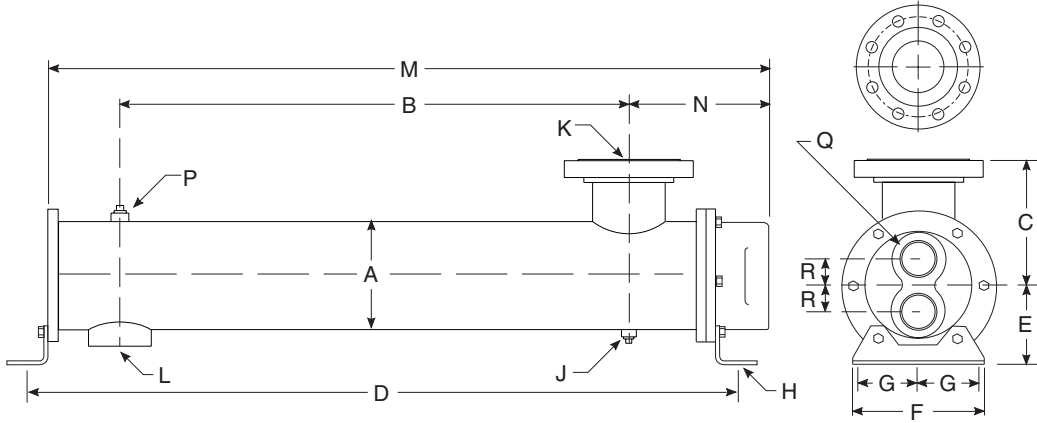

## TWO PASS (TP)

Model	M	N	Q NPT	R
UCF-1024	28.88			
UCF-1036	40.88	6.43	1.50	1.19
UCF-1048	52.88			
UCF-1224	29.17			
UCF-1236	41.17	7.23	2.00	1.44
UCF-1248	53.17			
UCF-1260	65.17			
UCF-1272	77.17			
UCF-1284	89.17			
UCF-1724	30.13			
UCF-1736	42.13	8.64	2.50	1.88
UCF-1748	54.13			
UCF-1760	66.13			
UCF-1772	78.13			
UCF-1784	90.13			
UCF-2036	43.91			
UCF-2048	55.91	11.07	3.00	2.50
UCF-2060	67.91			
UCF-2072	79.91			
UCF-2084	91.91			

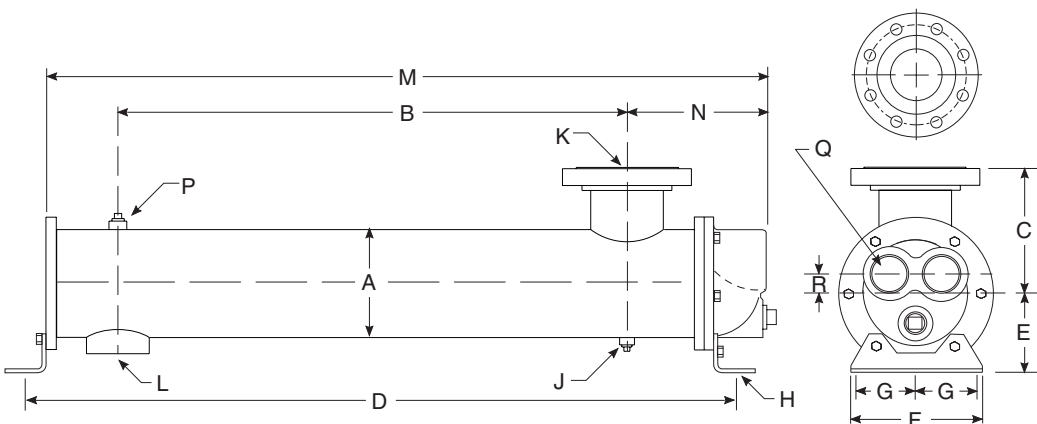

## FOUR PASS (FP)

Model	M	N	Q NPT	R	S
UCF-1024	29.21				
UCF-1036	41.21	6.77	1.00	.75	1.19
UCF-1048	53.21				
UCF-1224	29.58				
UCF-1236	41.58	7.64	1.50	1.06	1.44
UCF-1248	53.58				
UCF-1260	65.58				
UCF-1272	77.58				
UCF-1284	84.58				
UCF-1724	29.78				
UCF-1736	41.78	8.29	2.00	1.38	1.88
UCF-1748	53.78				
UCF-1760	65.78				
UCF-1772	77.78				
UCF-1784	89.78				
UCF-2036	44.00				
UCF-2048	56.00	11.16	2.50	1.75	2.50
UCF-2060	68.00				
UCF-2072	80.00				
UCF-2084	92.00				

## COMMON DIMENSIONS

Model	A	B	C	D	E	F	G	H	J NPT	K ANSI Flange	L NPT	P NPT	Weight	Model
UCF-1024		19.75		29.13									55.00	UCF-1024
UCF-1036	5.25	31.75	7.63	41.13	4.00	5.25	2.00	.44 x 1.00 thru slot	.375	3.00	1.50	.75	70.00	UCF-1036
UCF-1048		43.75		53.13									85.00	UCF-1048
UCF-1224		19.00		29.59									83.00	UCF-1224
UCF-1236		31.00		41.59									108.00	UCF-1236
UCF-1248	6.25	43.00	8.13	53.59	4.50	6.25	2.50	.44 x 1.00 thru slot	.375	4.00	2.00	.75	132.00	UCF-1248
UCF-1260		55.00		65.59									158.00	UCF-1260
UCF-1272		67.00		77.59									182.00	UCF-1272
UCF-1284		79.00		89.59									206.00	UCF-1284
UCF-1724		18.25		29.50									138.00	UCF-1724
UCF-1736		30.25		41.50									180.00	UCF-1736
UCF-1748	8.00	42.25	9.00	53.50	5.75	8.25	3.50	.44 x 1.00 thru slot	.375	5.00	2.00	1.00	219.00	UCF-1748
UCF-1760		54.25		65.50									258.00	UCF-1760
UCF-1772		66.25		77.50									300.00	UCF-1772
UCF-1784		78.25		89.50									342.00	UCF-1784
UCF-2036		29.00		42.63									620.00	UCF-2036
UCF-2048		41.00		54.63									670.00	UCF-2048
UCF-2060	10.75	53.00	10.38	66.63	8.00	11.50	5.00	.781 x 1.25 thru slot	.50	6.00	3.00	1.25	730.00	UCF-2060
UCF-2072		65.00		78.63									820.00	UCF-2072
UCF-2084		76.00		90.63									870.00	UCF-2084

note: AIHTI reserves the right to make reasonable design changes without notice.

# URCF Series *dimensions*

## REMOVABLE TUBE BUNDLE (U-TUBE DESIGN)

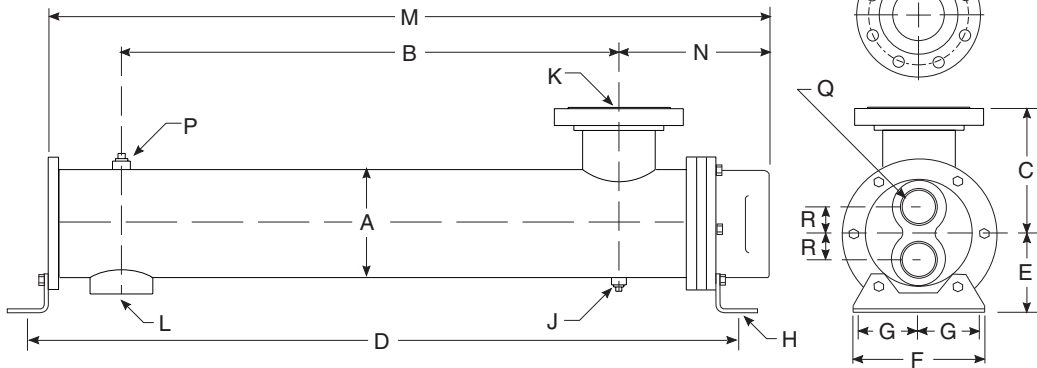

## TWO PASS (TP)

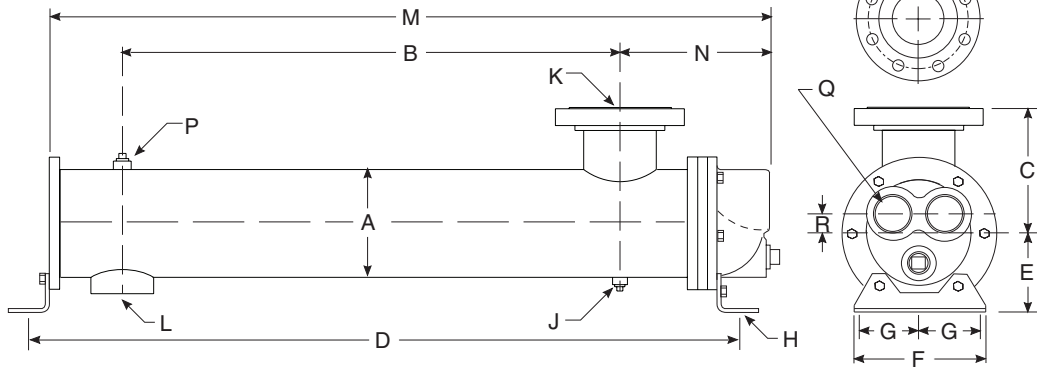

## FOUR PASS (FP)

Model	M	N	Q NPT	R
URCF-1024	28.88			
URCF-1036	40.88	6.43	1.50	1.19
URCF-1048	52.88			
URCF-1224	29.17			
URCF-1236	41.17	7.23	2.00	1.44
URCF-1248	53.17			
URCF-1260	65.17			
URCF-1272	77.17			
URCF-1284	89.17			
URCF-1724	30.13			
URCF-1736	42.13	8.64	2.50	1.88
URCF-1748	54.13			
URCF-1760	66.13			
URCF-1772	78.13			
URCF-1784	90.13			
URCF-2036	43.91			
URCF-2048	55.91	11.07	3.00	2.50
URCF-2060	67.91			
URCF-2072	79.91			
URCF-2084	91.91			

Model	M	N	Q NPT	R	S
URCF-1024	29.21				
URCF-1036	41.21	6.77	1.00	.75	1.19
URCF-1048	53.21				
URCF-1224	29.58				
URCF-1236	41.58	7.64	1.50	1.06	1.44
URCF-1248	53.58				
URCF-1260	65.58				
URCF-1272	77.58				
URCF-1284	84.58				
URCF-1724	29.78				
URCF-1736	41.78	8.29	2.00	1.38	1.88
URCF-1748	53.78				
URCF-1760	65.78				
URCF-1772	77.78				
URCF-1784	89.78				
URCF-2036	44.00				
URCF-2048	56.00	11.16	2.50	1.75	2.50
URCF-2060	68.00				
URCF-2072	80.00				
URCF-2084	92.00				

## COMMON DIMENSIONS

Model	A	B	C	D	E	F	G	H	J NPT	K ANSI Flange	L NPT	P NPT	Weight	Model
URCF-1024		19.75		29.13									55.00	URCF-1024
URCF-1036	5.25	31.75	7.63	41.13	4.00	5.25	2.00	.44 x 1.00 thru slot	.375	3.00	1.50	.75	70.00	URCF-1036
URCF-1048		43.75		53.13									85.00	URCF-1048
URCF-1224		19.00		29.59									83.00	URCF-1224
URCF-1236		31.00		41.59									108.00	URCF-1236
URCF-1248	6.25	43.00	8.13	53.59	4.50	6.25	2.50	.44 x 1.00 thru slot	.375	4.00	2.00	.75	132.00	URCF-1248
URCF-1260		55.00		65.59									158.00	URCF-1260
URCF-1272		67.00		77.59									182.00	URCF-1272
URCF-1284		79.00		89.59									206.00	URCF-1284
URCF-1724		18.25		29.50									138.00	URCF-1724
URCF-1736		30.25		41.50									180.00	URCF-1736
URCF-1748	8.00	42.25	9.00	53.50	5.75	8.25	3.50	.44 x 1.00 thru slot	.375	5.00	2.00	1.00	219.00	URCF-1748
URCF-1760		54.25		65.50									258.00	URCF-1760
URCF-1772		66.25		77.50									300.00	URCF-1772
URCF-1784		78.25		89.50									342.00	URCF-1784
URCF-2036		29.00		42.63									620.00	URCF-2036
URCF-2048		41.00		54.63									670.00	URCF-2048
URCF-2060	10.75	53.00	10.38	66.63	8.00	11.50	5.00	.781 x 1.25 thru slot	.50	6.00	3.00	1.25	730.00	URCF-2060
URCF-2072		65.00		78.63									820.00	URCF-2072
URCF-2084		76.00		90.63									870.00	URCF-2084

note: AIHTI reserves the right to make reasonable design changes without notice.

# Standard URCS stock unit for steam application

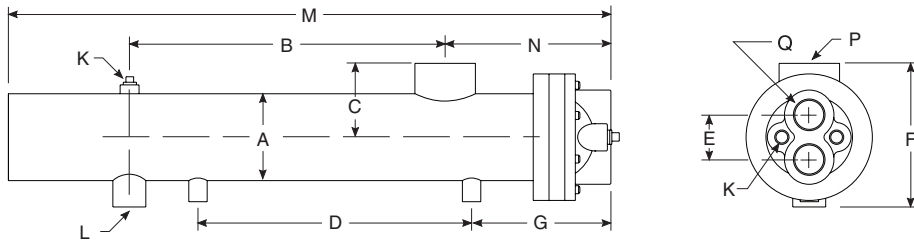

URCS-830

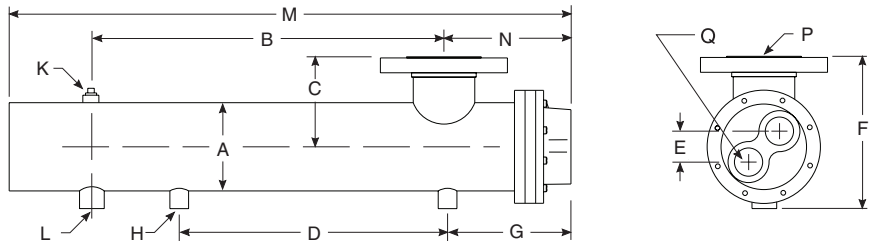

URCS-1230, URCS-1242, URCS-1254

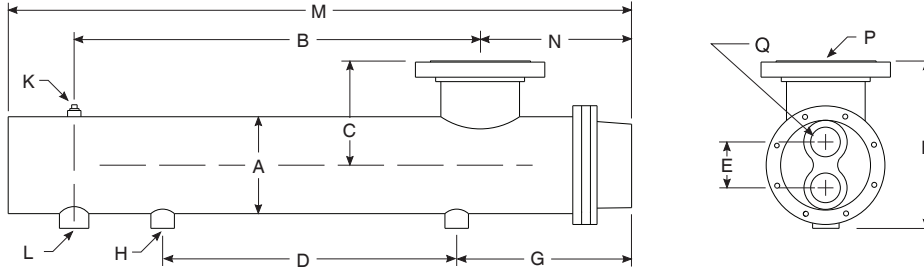

URCS-1754

## COMMON DIMENSIONS

MODEL	A	B	C	D	E	F	G	H NPT	K NPT	L NPT	M	N	P	Q NPT	WEIGHT
URCS-830-25180	4.25	15.00	3.56	13.00	2.38	6.81	5.75	1.00	.38	1.25	28.63	7.88	2.5" NPT	1.25	35
URCS-1230-25182	6.25	13.00	6.38	13.00	3.12	10.75	5.75	1.00	—	1.50	27.75	9.00	4" ANSI	2.00	69
URCS-1242-25183	6.25	25.00	6.38	19.00	3.12	10.75	8.75	1.00	—	1.50	39.75	9.00	4" ANSI	2.00	87
URCS-1254-25184	6.25	37.00	6.38	25.00	3.12	10.75	11.75	1.00	—	1.50	51.75	9.00	4" ANSI	2.00	105
URCS-1754-25185	8.00	34.50	8.75	25.00	4.50	14.00	14.88	1.25	—	2.00	53.00	12.88	6" ANSI	2.50	187

## STANDARD CONSTRUCTION MATERIALS & RATINGS

Construction Material		Optional Material	Standard Unit Ratings
Shell	Steel	Steel	Operating Pressure Tubes 100 psig Operating Pressure Shell 100 psig Operating Temperature 400 °F
Tubes	Copper	90/10 Cu. Ni. / S. Steel	
Baffle	Aluminum / Brass	Brass	
End Bonnet	Cast Iron	Brass / Stainless Steel	
Gasket	Viton O-Ring		

## SURFACE AREA

Model Number	Surface Area in Sq.ft.	
	1 / 4" O.D. Tubing	3 / 8" O.D. Tubing
URCS-830-25180	15.0	—
URCS-1230-25182	—	21.5
URCS-1242-25183	—	30.2
URCS-1254-25184	—	38.8
URCS-1754-25185	—	72.4

note: AIHTI reserves the right to make reasonable design changes without notice.

# UCN, URCN, UCF & URCF Series *installation & maintenance*

## Receiving / Installation

a) Inspect unit for any shipping damage before uncrating. Indicate all damages to the trucking firms' delivery person, and mark it on the receiving bill before accepting the freight. Make sure that there is no visible damage to the outside surface of the heat exchanger. The published weight information located in this brochure is approximate. True shipment weights are determined at the time of shipping and may vary. Approximate weight information published herein is for engineering approximation purposes and should not be used for exact shipping weight. Since the warranty is based upon the unit date code located on the model identification tags, removal or manipulation of the identification tags will void the manufacturers warranty.

b) When handling the shell & tube heat exchanger, special care should be taken to avoid dropping the unit since mishandling could cause the heat exchanger to crack and leak externally. Mishandling of the unit is not covered under the manufacturers warranty. All units are shipped with partial wood/corrugated cardboard containers for safe handling.

c) Storage: American Industrial heat exchangers are protected against the elements during shipment. If the heat exchanger cannot be installed and put into operation immediately upon receipt, certain precautions are required to prevent deterioration during storage. The responsibility for integrity of the heat exchanger(s) is assumed by the user. American Industrial will not be responsible for damage, corrosion, or other deterioration of the heat exchanger during transit or storage.

Proper storage practices are important when considering the high costs of repair or replacement, and the possible delays for items which require long lead times for manufacture. The following listed practices are provided solely as a convenience to the user, who shall make their own decision on whether to use all or any of them.

- 1) Heat exchangers not to be placed in immediate service, require precautionary measures to prevent corrosion or contamination.
- 2) Heat exchangers made of ferrous materials, may be pressure-tested using compressed air at the factory. Residual oil coating on the inside surfaces of the heat exchanger(s) as a result of flushing does not discount the possibility of internal corrosion. Upon receipt, fill the heat exchanger(s) with the appropriate grade of oil or apply a corrosion preventing inhibitor for storage.
- 3) Corrosion protection compounds for interior surfaces for long term storage or other applications are applied solely at the request of customers. Upon request, American Industrial can provide a customer approved corrosion preventative if available when included in the original purchase order specifications.
- 4) Remove all dirt, water, ice, or snow and wipe dry before moving heat exchanger(s) into storage. Heat exchangers are generally shipped empty, open drain plugs to remove any accumulated condensation moisture, then reseal. Accumulation of moisture usually indicates corrosion has already started and remedial action should be taken.
- 5) Store in a covered, environmentally stable area. The ideal storage environment for heat exchangers is in a dry, low-humidity atmosphere which is sealed to prevent the entry of blowing dust, rain, or snow. Maintain in atmospheric temperatures between 70°F and 105°F (Large temperature swings may cause condensation and moisture to form on steel components, threads, shell, etc...) Use thermometers and humidity indicators and maintain the atmosphere at 40% relative humidity, or lower.

d) Standard Enamel Coating: American Industrial provides its standard products with a normal base coat of oil base air cure enamel paint. The enamel paint is applied as a temporary protective and esthetic coating prior to shipment. While the standard enamel coating is durable, American Industrial does not warranty it as a long-term finish coating. It is strongly suggested that a more durable final coating be applied after installation or prior to long-term storage in a corrosive environment to cover any accidental scratches, enhance esthetics, and further prevent corrosion. It is the responsibility of the customer to provide regular maintenance against chips, scratches, etc... and regular touch up maintenance must be provided for long-term benefits and corrosion prevention.

e) Special Coatings: American Industrial offers as customer options, Air-Dry Epoxy, and Heresite (Air-Dry Phenolic) coatings

at additional cost. American Industrial offers special coatings upon request, however American Industrial does not warranty coatings to be a permanent solution for any equipment against corrosion. It is the responsibility of the customer to provide regular maintenance against chips, scratches, etc... and regular touch up maintenance must be provided for long-term benefits and corrosion prevention.

f) American Industrial recommends that the equipment supplied should be installed by qualified personnel who have solid understanding of system design, pressure and temperature ratings, and piping assembly. Verify the service conditions of the system prior to applying any shell & tube heat exchanger. If the system pressure or temperature does not fall within the parameters on model rating tag located on the heat exchanger, contact our factory prior to installation or operation.

g) Plan the installation to meet the requirements indicated on the piping installation diagram as illustrated above. It is recommended to put the hot fluid to be cooled through the shell side and the cold fluid through the tube side. The indicated port assembly sequence in the installation diagram maximizes the performance, and minimizes the possibility of thermal shock. In instances where the fluids are required to be reversed, hot fluid in the tubes and cold fluid in the shell the heat exchanger will work with reduced performance. Installation may be vertical or horizontal or a combination thereof. However, the installation must allow for complete draining of the heat exchanger regardless of two pass or four pass construction. Complete drainage is important to prevent the heat exchanger from freezing, over-heating of a fluid, or mineral deposit buildup.

For removable bundle heat exchangers, provide sufficient clearance at the stationary tube-sheet end to allow for the removal of the tube bundle from the shell. Bonnet can be removed to aid in cleaning the tubes without disassembling the tube bundle. For more information please contact American Industrial.

h) It is recommended to use flexible hose wherever possible to reduce vibration and allow slight movement. However, hoses are not required. Hydraulic carrying lines should be sized to handle the appropriate flow and to meet system pressure drop requirements

