



Air Cooled Liquid Cooler Application Request:

For AC - ACF - ACHM Series

Email form to: sales@aihti.com or engineering@aihti.com or fax to 434-757-1810

Contact Name _____ Telephone _____ Date _____

Company Name _____ Email _____

Address: _____ Fax _____

Hot Side

Cold Side

Fluid Type _____

Ambient Air _____

Density _____ lb/ft³

Altitude _____

Viscosity _____ cP

If available:

Thermal Conductivity _____ Btu/hr.ft.°F

Specific Heat _____ Btu/lb.°F

1. Flow Rate _____

1. Operating Pressure _____

2. Temperature In _____

2. Allowable Pressure Drop _____

3. Desired Temperature Out _____

ASME Code and Certified Yes No

4. Heat Load _____

To properly size the heat exchanger we need 3 of the 4 parameters on the Hot Side.

<p>Cabinet Material:</p> <p>Standard : Steel <input type="checkbox"/></p> <p>Options: Galvanized Steel <input type="checkbox"/></p> <p>Stainless Steel <input type="checkbox"/></p> <p>Coating</p> <p>Standard Enamaled Gray Paint <input type="checkbox"/></p> <p>Options: Epoxy Paint <input type="checkbox"/></p>	<p>Tubing Material:</p> <p>Standard : Copper <input type="checkbox"/></p> <p>90/10 Copper Nickel <input type="checkbox"/></p> <p>Stainless Steel <input type="checkbox"/></p> <p>Fins</p> <p>Standard Aluminum <input type="checkbox"/></p> <p>Options: Copper <input type="checkbox"/></p> <p>Optional Coating: Heresite <input type="checkbox"/></p>	<p>Motor</p> <p>60Hz: 230/460 Volt, 3 Phase <input type="checkbox"/></p> <p>115/230 Volt, 1 Phase <input type="checkbox"/></p> <p>575 Volt, 3 Phase <input type="checkbox"/></p> <p>50Hz 230/400 Volt, 3 Phase <input type="checkbox"/></p> <p>110/220 Volt, 1 Phase <input type="checkbox"/></p> <p>Hydraulic Motor <input type="checkbox"/></p>
--	--	---

Comment: _____



AC - ACF - ACHM SERIES



ACF SERIES

ACHM SERIES

AC SERIES

Air Cooled

LIQUID COOLERS

- Thermal capacity to 100 hp (75 Kw).
- Computerized selection program.
- Standard ports NPT, optional SAE straight thread or flange connections.
- Optional: built-in bypass relief valve.
- Operating temperature of 300° F and pressure of 300PSI.
- Computer generated data sheet available for any application
- Custom designs to fit your needs.
- Cools: Fluid Power Systems, Lubrication Systems, Hydraulic Presses, Gear Drives, Torque Convertors, Machine Tools, Etc...

AC, ACF & ACHM Series *overview*

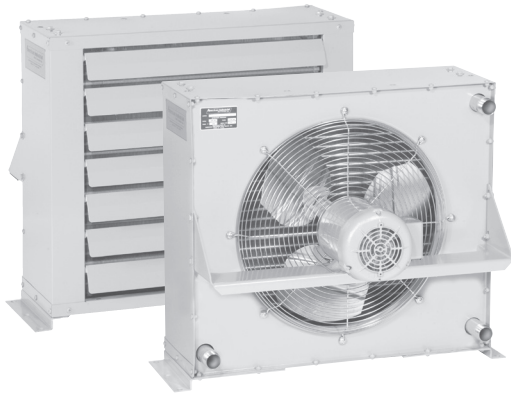

AC SERIES with electric drive

Industrial air-cooled liquid coolers, three row rolled tube servicable core heat exchangers with direct electric drive cooling fan, OSHA guard, and air directing louvers. Rated operating temperature of 300°F at 300 PSIG. Services standard flow rates from 2 to 120 GPM. Thermal capacity up to 100 hp (75Kw). NPT, flange, or SAE straight thread port connections. Optional built-in bypass relief valve 30 PSI or 65 PSI. Can be modified to meet your requirements. Suitable for most hydraulic oils, lubrications oils, synthetic compressor oils, phosphate ester, ethylene glycol, and many other fluids compatible with listed material.

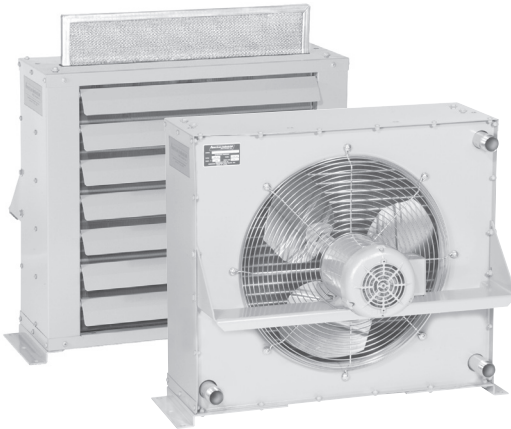

ACF SERIES with electric drive

Industrial air-cooled liquid coolers, three row rolled tube heat exchangers with washable internal filter located between the fan and core, direct electric drive cooling fan, OSHA guard, and air directing louvers. Washable filter helps prevent airborne dust and debris from collecting on the core fins for continued optimum performance. Filter can be easily removed within minutes from the filter track, cleaned or replaced for continued service. Rated operating temperature of 300°F at 300 PSIG. Thermal capacity up to 100 hp (75Kw). Optional built-in bypass relief valve 30 PSI or 65 PSI. Can be modified to meet your requirements. The ACF series can be used in environments such as Sawmills or foundries, etc...where excessive airborne dust or debris may be present.

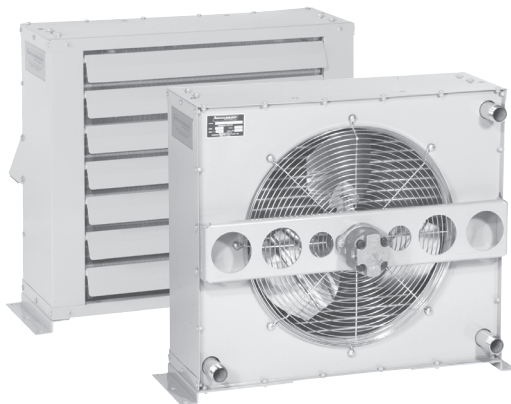

ACHM SERIES with hydraulic drive

Industrial air-cooled liquid coolers, three row rolled tube heat exchangers with hydraulic drive cooling fan, OSHA guard, and air directing louvers. Rated operating temperature of 300°F at 300 PSIG. Services standard flow rates from 2 to 120 GPM. Thermal capacity up to 100 hp (75Kw). NPT, flange, or SAE straight thread port connections. Optional built-in bypass relief valve 30 PSI or 65 PSI. Can be modified to meet your requirements. Suitable for most hydraulic oils, lubrications oils, synthetic compressor oils, phosphate ester, ethylene glycol, and many other fluids compatible with listed material.



AOCH SERIES

Industrial air-cooled liquid coolers, dimensionally similar to AC & ACHM Series with higher capacity and performance. Six row rolled tube heat exchangers with direct electric drive cooling fan, OSHA guard, air directing louvers and Servicable Core®. Rated operating temperature of 300°F at 300 PSIG. Can be modified to meet your requirements. Suitable for most hydraulic oils, lubrications oils, synthetic compressor oils, phosphate ester, ethylene glycol, and many other fluids compatible with listed material.

HIGH PERFORMANCE TURBULATOR



Exclusive American Industrial Turbulators (installed in every flow tube) increase heat transfer by more than 100%.

American Industrial Turbulators eliminate the laminar flow condition normally associated with other smooth tube heat exchangers. High viscosity hydraulic and lubricating oils are easily cooled by this new state-of-the-art turbulator.

SUPERIOR COOLING FINNS

Seamless copper tubes are mechanically bonded to highly efficient aluminum cooling fins. Die-formed fin collars provide a durable precision fit for maximum heat transfer.

Custom fin design forces air to become turbulent and carry heat away more efficiently than old flat fin designs.

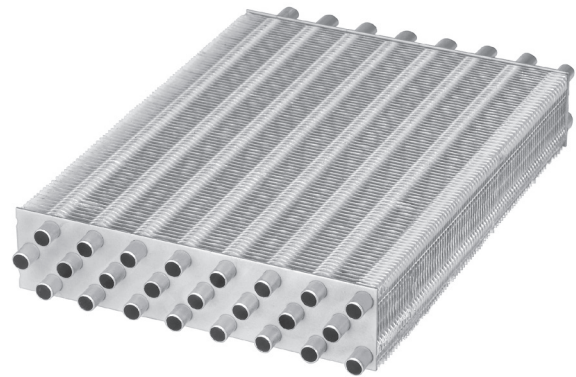

CONSTRUCTION MATERIALS & RATINGS

Standard Construction Materials		Optional Construction Materials	Standard Unit Ratings	
Tubes	Copper	Carbon Steel	Operating Pressure	300 psig
Fins	Aluminum	Copper	Operating Temperature	300 °F
Turbulators	Steel	Brass	Max. Flow Internal Relief	38 gpm
Manifold	Steel	Stainless Steel	Max. Fan Over-speed	10 %
Connection pipes	Steel	Stainless Steel	Max. Ambient Conditions	104 °F
Cabinet & frame	Steel	Galvanized Steel, 316L Stainless Steel	Altitude	0-3300 ft.
Fan Blade	Aluminum with steel hub	Plastic, Non-sparking		
Fan Guard	Zinc plated steel			

Accessories

Electrical Temperature controller with Bulb Well Assembly (for Air / Liquid Coolers)

Part Number	Description
310-4001	TC-511 with 5-Foot Capillary Tube & Bulb Well
310-4002	TC-511 with 20-Foot Capillary Tube & Bulb Well
310-2005	Replacement Bulb Well TC-511



AC, ACF & ACHM Series performance

ONE PASS

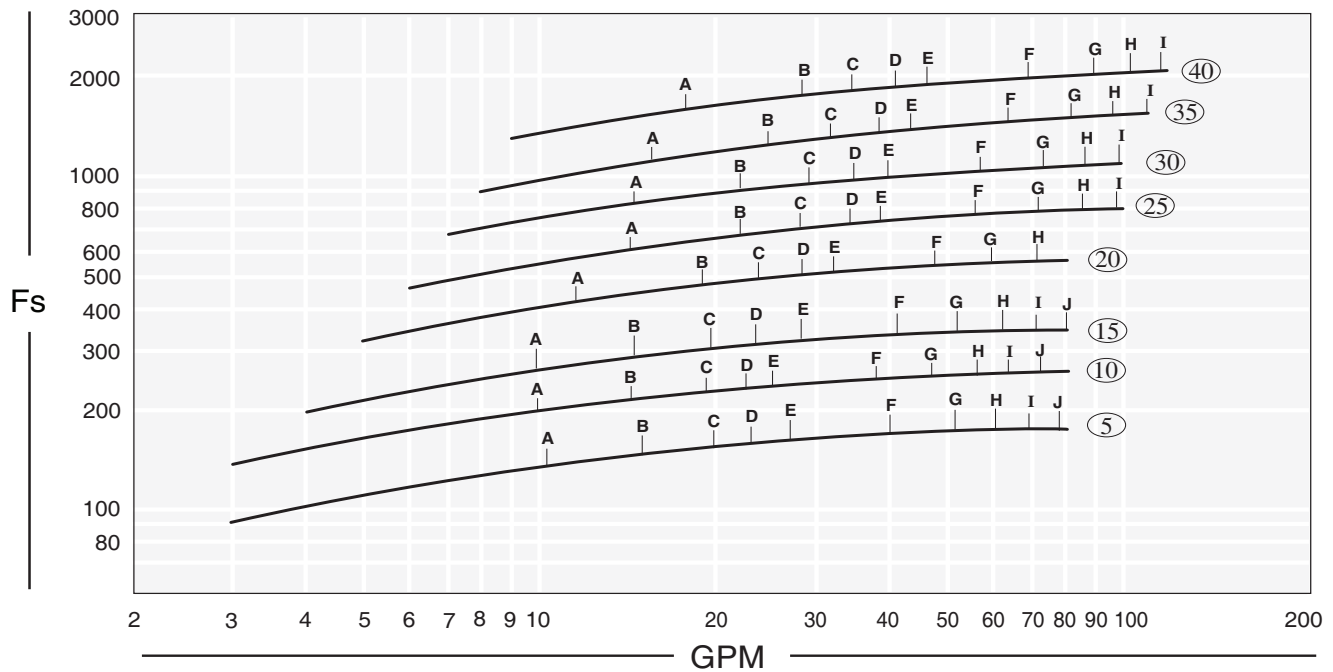

TWO PASS

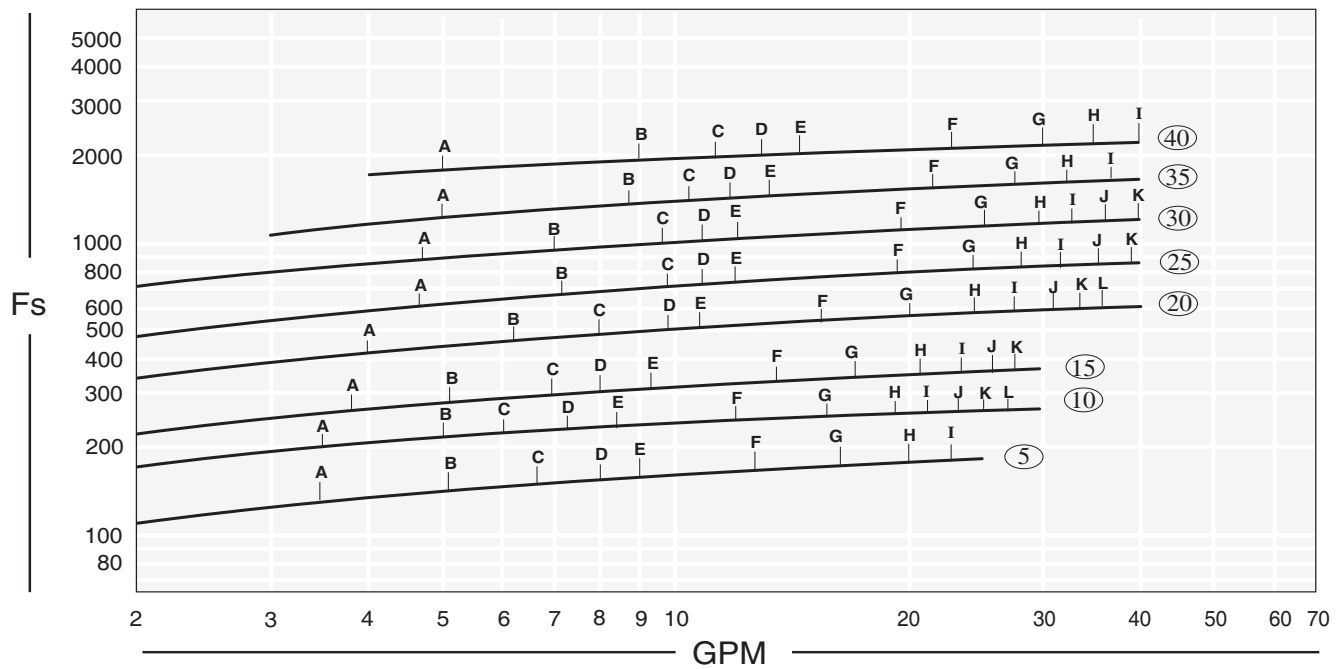

PERFORMANCE CALCULATION	OIL PRESSURE DROP (PSI) CODE
$F_s = \frac{\text{Horsepower to be removed (HP)} \times 2545 \times C_v}{\text{°F (Oil Leaving* - Ambient Air Entering)}} = \frac{\text{BTU}}{\text{hr °F}}$	A = 1 PSI D = 4 PSI G = 15 PSI J = 30 PSI B = 2 PSI E = 5 PSI H = 20 PSI K = 35 PSI C = 3 PSI F = 10 PSI I = 25 PSI L = 40 PSI

*Represents desired fluid leaving the cooler.

Note: When a model selection has been made, record whether the selection was from the one pass curve or the two pass curve so that the unit can be properly plumbed. Incorrect installation can seriously affect the performance.

AC, ACF & ACHM Series selection

Sizing

The performance curves provided are for petroleum oil at 50 ssu viscosity. However, fluids with characteristics other than the above mentioned may be used by applying a correction factor.

Heat Load

If the heat load is unknown, a horsepower value can be calculated by first determining the systems total potential. For a basic hydraulic system, it is helpful to know whether the system is open loop (with a large reservoir) or closed loop (normally on mobile equipment, with a very small reservoir). System potentials may be calculated quickly by using one of the two methods below.

There are some system parameters that will be required to properly accomplish the sizing calculations. Without system parameters, it is difficult to determine the optimal heat exchanger size. Normally many of the system parameters can be found on hydraulic schematics or on tags located on the actual equipment. Following are some basic parameters that you should try to acquire before attempting the sizing calculations. However, it is not necessary to have every parameter listed below.

- Main system flow rate (gpm) & operating pressure (psi).
- Electric motor HP driving hydraulic pump (if more than one add up the Hp for all).
- Desired temperature (°F).
- Fluid type (SAE 10, 20, 30, etc....).
- Ambient air temperature (warmest day).
- Desired fan drive (hydraulic, electric, 12-24V DC, etc...).
- BTU's or HP to be cooled (normally given for lubrication systems).
- Maximum pressure drop allowed through the heat exchanger.
- Space available for heat exchanger (LxWxH).
- External air condition (dirty, papers, etc...).

Method 1

Normally used for open loop circuits. Multiply the main hydraulic systems Electric Motor Name plate Horsepower by a heat removal factor (normally 30-50%).

Example: 50 HP motor x 0.3 = 15 HP heat load

Method 2

Normally used when the HP input potential is unknown or for mobile applications where diesel engines operate the entire system.

Multiply system pressure by the flow rate of the main system divided by 1714 equals system potential (HP). Multiply the system HP by a heat removal factor (Normally 25-35%). Note: In some closed loop systems only a portion of the total system flow is directed through the heat exchanger. This may affect the cooler selection process substantially. You may contact our factory for additional technical assistance.

Example: $\frac{(2000 \text{ psi} \times 30 \text{ gpm})}{1714} = [35 \text{ HP} \times .25] = 8.75 \text{ HP heat load}$

Determining Fs value

To determine the proper size heat exchanger for your application, use the following equation to first determine the (Fs) factor:

$$F_s = \frac{\text{heat load (HP)} \times 2545 \times C_v}{\text{°F (oil leaving - air entering)}}$$

Example:

Heat load = 8.75 HP

Cv = 1.14 (SAE 20) determined from chart. [Located on page 5.]

Desired operating temperature = 120 °F

Ambient air temp. = 100 °F

$$F_s = \frac{8.75 \times 2545 \times 1.14}{120 \text{ °F} - 100 \text{ °F}} = 1269$$

Selection

To select a model, locate the flow rate (GPM) at the bottom of the flow vs Fs graph (on page 4). Proceed upward until the GPM flow rate intersects with the calculated Fs. The curve closest above the intersection point will meet these conditions.

Example: **Fs = 1269 = Model = AC,ACHM,ACF - 35**
GPM = 40
PASSES = 1

Pressure differentials

Determine the oil pressure drop from the curves as indicated. For viscosities other than 50 ssu, multiply the actual indicated pressure drop for your GPM flow by the value shown in the pressure differential curve for your viscosity value.

Example: Model 35 @ 40 gpm & 50 ssu -1 pass curve-
 Indicated pressure drop 4.2 psi (Approx)
 { 4.2 psi x 2.8Cp (for SAE-20 oil) } = 11.76 corrected psi

Average Liquid Temperature	Cv VISCOSITY CORRECTION FACTORS																
	SAE 5	SAE 10	SAE 20	SAE 30	SAE 40	ISO 22	ISO 32	ISO 46	ISO 68	ISO 100	ISO 150	ISO 220	ISO 320	MIL-L-7808	POLYGLYCOL	PHOSPHATE ESTER	50% ETHYLENE GLYCOL & WATER
100	1.11	1.15	1.25	1.38	1.45	1.08	1.14	1.18	1.26	1.37	1.43	1.56	1.84	1.19	0.92	0.83	0.85
110	1.09	1.12	1.20	1.32	1.40	1.06	1.13	1.16	1.25	1.31	1.39	1.48	1.67	1.14	0.89	0.80	0.84
120	1.06	1.10	1.17	1.27	1.35	1.04	1.11	1.14	1.20	1.27	1.35	1.40	1.53	1.09	0.88	0.79	0.84
130	1.04	1.08	1.13	1.24	1.29	1.03	1.09	1.13	1.17	1.24	1.30	1.34	1.44	1.05	0.85	0.77	0.83
140	1.03	1.05	1.11	1.19	1.25	1.02	1.08	1.10	1.16	1.20	1.26	1.30	1.39	1.03	0.84	0.76	0.82
150	1.01	1.04	1.09	1.16	1.22	1.02	1.06	1.09	1.13	1.17	1.22	1.27	1.33	1.01	0.83	0.74	0.82
200	0.98	0.99	1.01	1.04	1.07	0.98	0.99	1.00	1.01	1.02	1.08	1.09	1.14	0.98	0.79	0.71	0.80
250	0.95	0.96	0.97	0.98	0.99	0.95	0.96	0.96	0.96	0.97	0.99	1.01	1.02	0.97	0.76	0.69	0.79

Average Liquid Temperature	Cp PRESSURE DROP CORRECTION FACTORS																
	SAE 5	SAE 10	SAE 20	SAE 30	SAE 40	ISO 22	ISO 32	ISO 46	ISO 68	ISO 100	ISO 150	ISO 220	ISO 320	MIL-L-7808	POLYGLYCOL	PHOSPHATE ESTER	50% ETHYLENE GLYCOL & WATER
100	2.00	2.40	4.40	6.40	8.80	1.07	1.53	1.82	2.54	4.19	6.44	9.38	13.56	1.26	3.00	3.50	0.730
110	1.70	2.10	3.60	5.10	6.70	1.04	1.45	1.72	2.35	3.73	5.70	8.33	11.63	1.20	2.40	2.90	0.720
120	1.50	1.80	3.00	4.20	5.60	1.02	1.38	1.60	2.15	3.26	4.91	7.23	9.73	1.14	2.10	2.50	0.709
130	1.40	1.60	2.60	3.40	4.50	0.99	1.30	1.49	1.94	2.80	4.14	6.19	7.80	1.08	1.90	2.20	0.698
140	1.30	1.50	2.23	2.90	3.70	0.97	1.23	1.38	1.75	2.38	3.47	5.20	6.11	1.03	1.90	2.00	0.686
150	1.20	1.30	1.90	2.50	3.10	0.95	1.17	1.30	1.61	2.04	2.90	4.35	4.77	0.98	1.70	1.90	0.676
200	0.93	0.96	1.20	1.40	1.60	0.89	0.99	1.08	1.18	1.33	1.59	1.74	1.95	0.90	1.20	1.30	0.635
250	0.81	0.82	0.92	0.97	1.05	0.85	0.93	0.96	1.03	1.11	1.21	1.22	1.23	0.83	1.00	1.05	0.556

note: AIHTI reserves the right to make reasonable design changes without notice.

AC Series dimensions

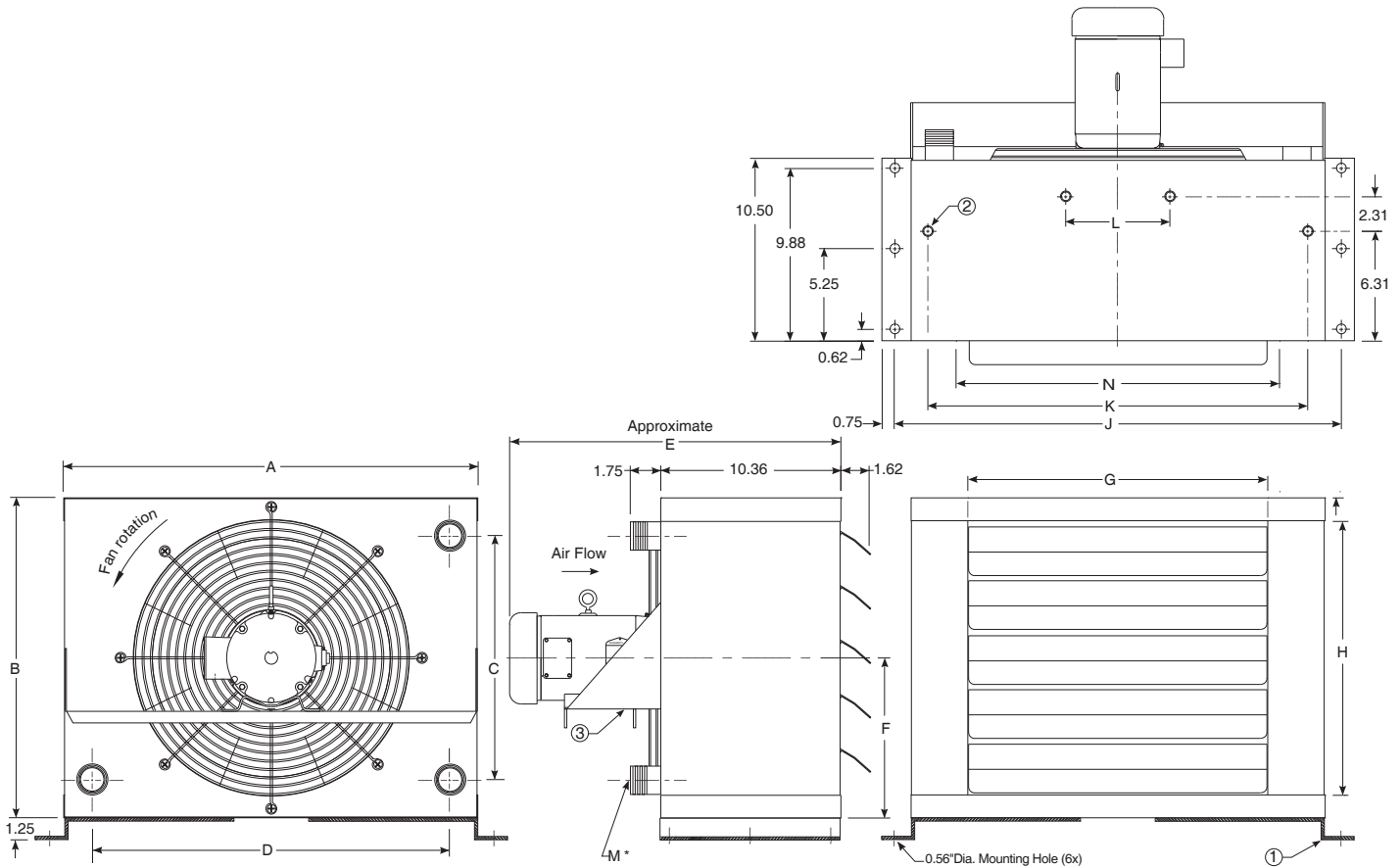

DIMENSIONS (inches)													
Model	A	B	C	D	E	F	G	H	J	K	L	M NPT	M SAE
AC - 5 - *	14.81	11.81	7.69	11.69	17.56	5.90	8.31	9.19	16.81	12.94	—	1.00	16 SAE
AC - 10 - *	19.00	13.13	8.88	15.88	17.13	6.56	12.50	10.50	21.00	17.13	—	1.00	1 5/16 - 12UN-2B
AC - 15 - *	20.38	15.75	11.50	17.25	17.44	7.88	13.88	13.12	22.38	18.50	—	1.00	Thread
AC - 20 - *	23.81	18.38	14.00	20.56	17.56	9.19	17.19	15.75	25.81	21.81	—	1.25	
AC - 25 - *	26.68	23.63	19.25	23.56	17.56	11.81	20.19	21.00	28.68	24.81	—	1.25	20 SAE
AC - 30 - *	31.63	27.56	23.19	28.50	17.63	13.78	25.13	24.94	33.63	29.75	11.00	1.25	1 5/8 - 12UN-2B
AC - 35 - *	33.81	30.19	25.81	30.69	20.75	15.09	27.31	27.56	35.81	31.94	11.00	1.25	Thread
AC - 40 - *	41.63	36.75	32.38	38.50	19.63	18.38	35.13	34.12	43.63	39.75	13.25	1.25	

* Represents options.

Notes:

- 1) Removable base mounting brackets are supplied with unit at no additional charge.
- 2) 1/2-12 UNC-2B Tabs, 4 points, 8 points on models AC - 30,35 & 40 (top & bottom) for optional mounting purposes.
- 3) Motor mounting bracket is rotated 90 degrees on AC - 5 & 10 units.
- 4) Louvers are manually adjustable. However, all units are available with a screen front as an option (specify when ordering).
- 5) All units are available with an optional preset 30 or 65-psi pressure bypass valve. (see note "I" in maintenance on page 143)
- 6) All units can be connected in one or two pass configuration. Refer to piping instructions for detailed operating and maintenance information.

Example of a model:

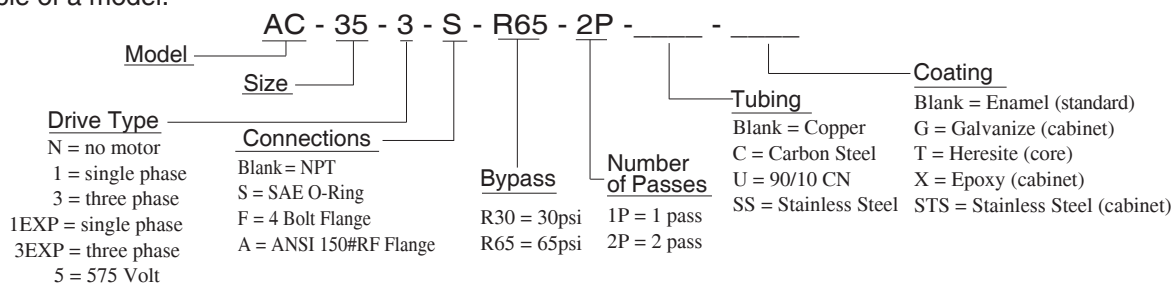

note: AIHTI reserves the right to make reasonable design changes without notice.

AC ELECTRIC MOTOR @ 60 Hz. DATA

Model	Horse Power	Phase	Hz	Volts	RPM	NEMA Frame	Type	Full Load Amperes	Service Factor	Thermal Overload
AC-5, AC-10, AC-15, AC-20	1/4	1	60	115/230	1800	48	TEFC	2.6/1.3	1.15	No
AC-5, AC-10, AC-15, AC-20	1/4	3	60	208-230/460	1800	48	TEFC	1.4/0.7	1.0	No
AC-5, AC-10, AC-15, AC-20	1/3	3	60	575	1800	56	TEFC	0.6	1.15	No
AC-25 , AC-30	1/4	1	60	115/208-230	1200	48	TEFC	6.4/3.2	1.0	No
AC-25 , AC-30	1/4	3	60	208-230/460	1200	48	TEFC	1.4/0.7	1.0	No
AC-25 , AC-30	1/2	3	60	575	1200	56	TEFC	1.0	1.15	No
AC-35 , AC-40	1/2	1	60	115/208-230	1200	56	TEFC	8.0/4.0	1.0	No
AC-35 , AC-40	1/2	3	60	208-230/460	1200	56	TEFC	2.4/1.2	1.0	No
AC-35 , AC-40	1/2	3	60	575	1200	56	TEFC	1.0	1.15	No

AC ELECTRIC MOTOR @ 50 Hz. DATA

Model	Horse Power	Phase	Hz	Volts	RPM	NEMA Frame	Type	Full Load Amperes	Service Factor	Thermal Overload
AC-5,10,15,20	1/3	1	50	110/220	1500	56	TEFC	6.4/3.2	1.15	No
AC-5,10,15,20	1/4	3	50	220/380	1500	48	TEFC	1.7/1.0	1.15	No
AC-25 , AC-30	1/3	1	50	110/220	1500	56	TEFC	6.4/3.2	1.15	No
AC-25 , AC-30	1/4	3	50	220/380	1500	48	TEFC	1.7/1.0	1.15	No
AC-35 , AC-40	1/2	1	50	110/220	1500	56	TEFC	6.4/3.6	1.0	No
AC-35 , AC-40	1/2	3	50	220/380	1500	56	TEFC	2.0/1.15	1.15	No

CLASS I,DIV.1, GROUP D or CLASS II,DIV.2, GROUP F & G EXPLOSION PROOF MOTOR DATA

Model	Horse Power	Phase	Hz	Volts	RPM	NEMA Frame	Enclosure Type	Full Load Amperes	Service Factor	Thermal Overload
AC-5,10,15-EXP	1/4	1	60	115-208/230	1800	48	X-PROOF	5.0/2.5	1.0	Yes
AC-5,10,15-EXP	1/4	3	60	208-230/460	1800	48	X-PROOF	1.4/0.7	1.0	Yes
AC-20-EXP	1/2	1	60	115-208/230	1800	48	X-PROOF	7.4/3.7	1.0	Yes
AC-20-EXP	1/2	3	60	208-230/460	1800	48	X-PROOF	2.0/1.0	1.0	Yse
AC-25,30-EXP	1/2	1	60	115/230	1200	56	X-PROOF	8.0/4.0	1.0	Yes
AC-25,30-EXP	1/2	3	60	208-230/460	1200	56	X-PROOF	2.4/1.2	1.0	Yes
AC-35,40-EXP	1.0	1	60	115-208/230	1200	184	X-PROOF	14.0/7.0	1.0	No
AC-35,40-EXP	1.0	3	60	230/460	1200	56	X-PROOF	3.8/1.9	1.0	No

NOTE: All of the AC Series explosion proof motors are available in 50hz upon request as a special

ELECTRIC MOTOR NOTES:

- 1) All motors are NEMA, high efficiency
- 2) Motor electrical ratings are an approximate guide and may vary between motor manufacturers. Consult ratings on motor data plate prior to installation and operation.
- 3) High temperature, severe duty, chemical, IEC, Canadian Standards Association, and Underwriters Laboratory recognized motors are available upon request.
- 4) American Industrial reserves the right to enact changes to motor brand, type and ratings regarding horsepower, RPM,FLA,and service factor for standard products without notice. All specific requirements will be honored without change.
- 5) Fan rotation is clockwise when facing the motor shaft.
- 6) The above motors contain factory lubricated shielded ball bearings (no additional lubrication is required).
- 7) Abbreviation Index
 TEFC.....Totally Enclosed, Fan Cooled
 X-PROOF.....Explosion Proof

ACF Series dimensions

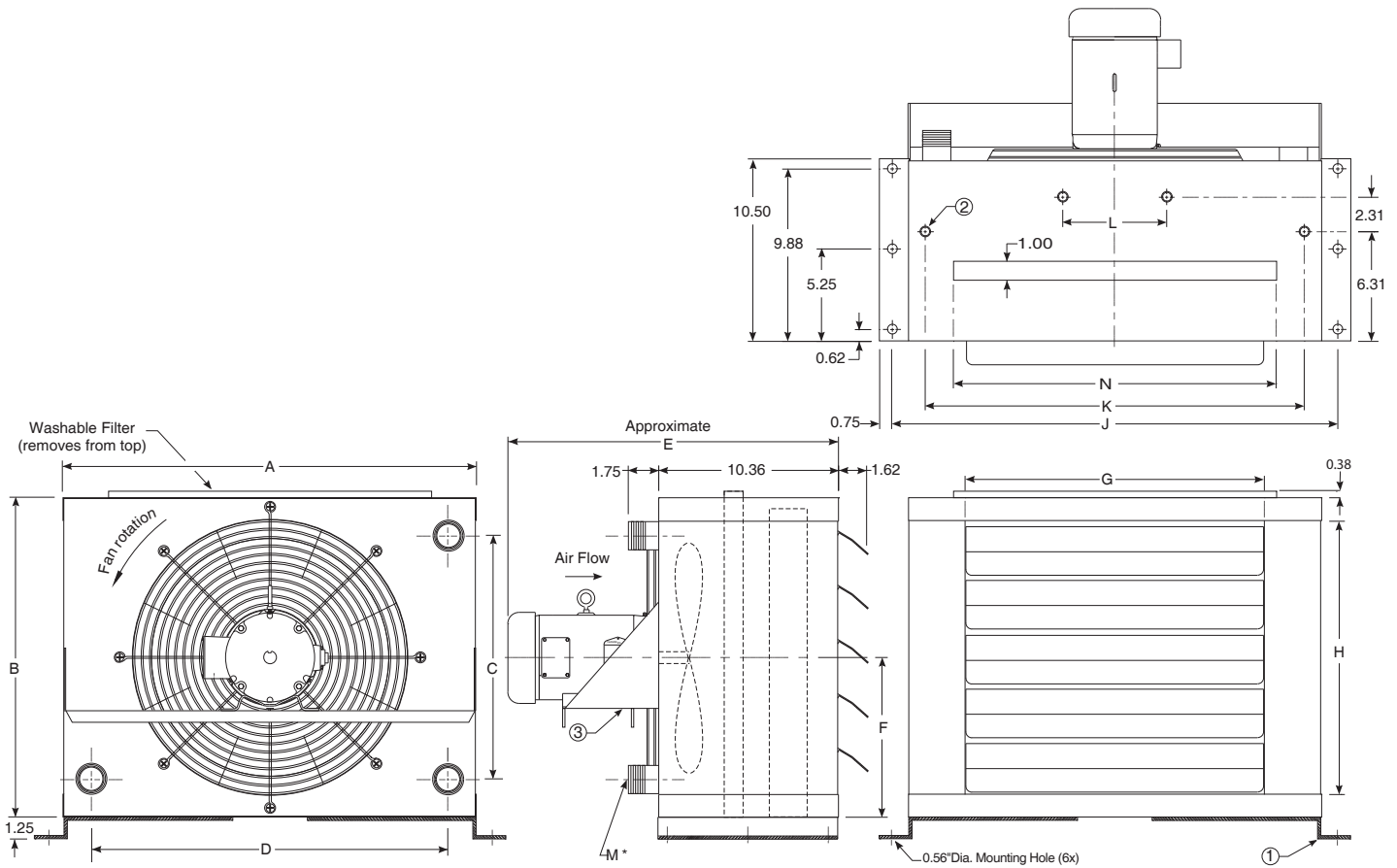

DIMENSIONS (inches)													
Model	A	B	C	D	E	F	G	H	J	K	L	M NPT	M SAE
ACF - 5 - *	14.81	11.81	7.69	11.69	17.56	5.90	8.31	9.19	16.81	12.94	—	1.00	16 SAE
ACF - 10 - *	19.00	13.13	8.88	15.88	17.13	6.56	12.50	10.50	21.00	17.13	—	1.00	1 5/16 - 12UN-2B Thread
ACF - 15 - *	20.38	15.75	11.50	17.25	17.44	7.88	13.88	13.12	22.38	18.50	—	1.00	
ACF - 20 - *	23.81	18.38	14.00	20.56	17.56	9.19	17.19	15.75	25.81	21.81	—	1.25	
ACF - 25 - *	26.68	23.63	19.25	23.56	17.56	11.81	20.19	21.00	28.68	24.81	—	1.25	20 SAE
ACF - 30 - *	31.63	27.56	23.19	28.50	17.63	13.78	25.13	24.94	33.63	29.75	11.00	1.25	1 5/8 - 12UN-2B Thread
ACF - 35 - *	33.81	30.19	25.81	30.69	20.75	15.09	27.31	27.56	35.81	31.94	11.00	1.25	
ACF - 40 - *	41.63	36.75	32.38	38.50	19.63	18.38	35.13	34.12	43.63	39.75	13.25	1.25	

* Represents options.

Notes:

- 1) Removable base mounting brackets are supplied with unit at no additional charge.
- 2) 1/2-12 UNC-2B Tabs, 4 points, 8 points on models ACF - 30, 35 & 40 (top & bottom) for optional mounting purposes.
- 3) Motor mounting bracket is rotated 90 degrees on ACF - 5 & 10 units.
- 4) Louvers are manually adjustable. However, all units are available with a screen front as an option (specify when ordering).
- 5) All units are available with an optional preset 30 or 65-psi pressure bypass valve. (see note "i" in maintenance on page 143)
- 6) All units can be connected in one or two pass configuration. Refer to piping instructions for detailed operating and maintenance information.
- 7) Filters are flame retardant, washable, and reusable woven synthetic with polyglass.

Example of a model:

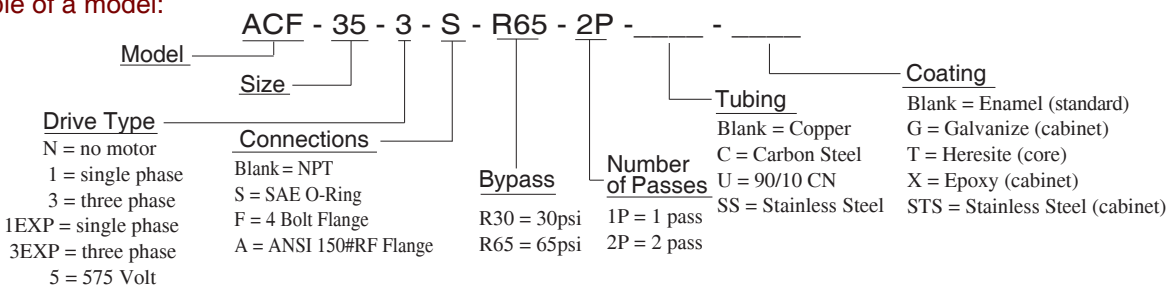

ACF ELECTRIC MOTOR @ 60 Hz. DATA

Model	Horse Power	Phase	Hz	Volts	RPM	NEMA Frame	Type	Full Load Amperes	Service Factor	Thermal Overload
ACF-5,10,15	1/4	1	60	115/230	1800	48	TEFC	2.6/1.3	1.15	No
ACF-5,10,15	1/4	3	60	208-230/460	1800	48	TEFC	1.4/0.7	1.0	No
ACF-5,10,15	1/3	3	60	575	1800	56	TEFC	0.6	1.15	No
ACF-20	1/2	1	60	115/208-230	1800	48	TEFC	7.4/3.7	1.0	No
ACF-20	1/2	3	60	208/230-460	1800	48	TEFC	2.0/1.0	1.0	No
ACF-20	1/3	3	60	575	1800	56	TEFC	0.6	1.15	No
ACF-25 , ACF-30	1/2	1	60	115/208-230	1200	56	TEFC	8.0/4.0	1.0	No
ACF-25 , ACF-30	1/2	3	60	208-230/460	1200	56	TEFC	2.4/1.2	1.0	No
ACF-25 , ACF-30	1/2	3	60	575	1200	56	TEFC	1.0	1.15	No
ACF-35 , ACF-40	1.0	1	60	115/208-230	1200	184	TEFC	14.0/7.0	1.0	No
ACF-35 , ACF-40	1.0	3	60	208-230/460	1200	56	TEFC	3.6/1.8	1.15	No
ACF-35 , ACF-40	1/2	3	60	575	1200	56	TEFC	1.0	1.15	No

ACF ELECTRIC MOTOR @ 50 Hz. DATA

Model	Horse Power	Phase	Hz	Volts	RPM	NEMA Frame	Type	Full Load Amperes	Service Factor	Thermal Overload
ACF-5,10,15	1/3	1	50	110/220	1500	56	TEFC	6.4/3.2	1.15	No
ACF-5,10,15	1/2	3	50	220/380	1500	56	TEFC	2.0/1.15	1.0	No
ACF-20	1/2	1	50	110/220	1500	56	TEFC	7.2/3.6	1.0	No
ACF-20	1/2	3	50	220/380	1500	56	TEFC	2.0/1.15	1.0	No
ACF-25,30	1/2	1	50	110/220	1500	48	TEFC	7.2/3.6	1.0	No
ACF-25,30	1/2	3	50	220/380	1500	56	TEFC	2.0/1.15	1.0	No
ACF-35,40	1.0	1	50	110/220	1500	56	TEFC	12.4/6.2	1.0	No
ACF-35,40	1.0	3	50	220/380	1500	143T	TEFC	3.5/2.0	1.0	No

CLASS I,DIV.1, GROUP D or CLASS II,DIV.2, GROUP F & G EXPLOSION PROOF MOTOR DATA

Model	Horse Power	Phase	Hz	Volts	RPM	NEMA Frame	Enclosure Type	Full Load Amperes	Service Factor	Thermal Overload
ACF - 5,10,15 - 1 - EXP	1 / 4	1	60	115-208 / 230	1800	48	X-PROOF	5.0/2.5	1.0	Yes
ACF - 5,10,15 - 3 - EXP	1 / 4	3	60	208-230 / 460	1800	48	X-PROOF	1.4/0.7	1.0	Yes
ACF - 20 - 1 - EXP	1 / 2	1	60	115-208 / 230	1800	48	X-PROOF	7.4/3.7	1.0	Yes
ACF - 20 - 3 - EXP	1 / 2	3	60	208-230 / 460	1800	48	X-PROOF	2.0/1.0	1.0	Yes
ACF - 25,30 - 1 - EXP	1 / 2	1	60	115 / 230	1200	56	X-PROOF	8.0/4.0	1.0	Yes
ACF - 25,30 - 3 - EXP	1 / 2	3	60	208-230 / 460	1200	56	X-PROOF	2.4/1.2	1.0	Yes
ACF - 35,40 - 1 - EXP	1.0	1	60	115-208/230	1200	184	X-PROOF	14.0/7.0	1.0	No
ACF - 35,40 - 3 - EXP	1.0	3	60	230/460	1200	56	X-PROOF	3.8/1.9	1.0	No

NOTE: All of the ACF Series explosion proof motors are available in 50hz upon request as a special

ELECTRIC MOTOR NOTES:

- 1) All motors are NEMA, high efficiency
- 2) Motor electrical ratings are an approximate guide and may vary between motor manufacturers. Consult ratings on motor data plate prior to installation and operation.
- 3) High temperature, severe duty, chemical, IEC, Canadian Standards Association, and Underwriters Laboratory recognized motors are available upon request.
- 4) American Industrial reserves the right to enact changes to motor brand, type and ratings regarding horsepower, RPM,FLA,and

service factor for standard products without notice. All specific requirements will be honored without change.

- 5) Fan rotation is clockwise when facing the motor shaft.
- 6) The above motors contain factory lubricated shielded ball bearings (no additional lubrication is required).

7) Abbreviation Index

TEFC.....Totally Enclosed, Fan Cooled
X-PROOF.....Explosion Proof

ACHM SERIES DIMENSIONS

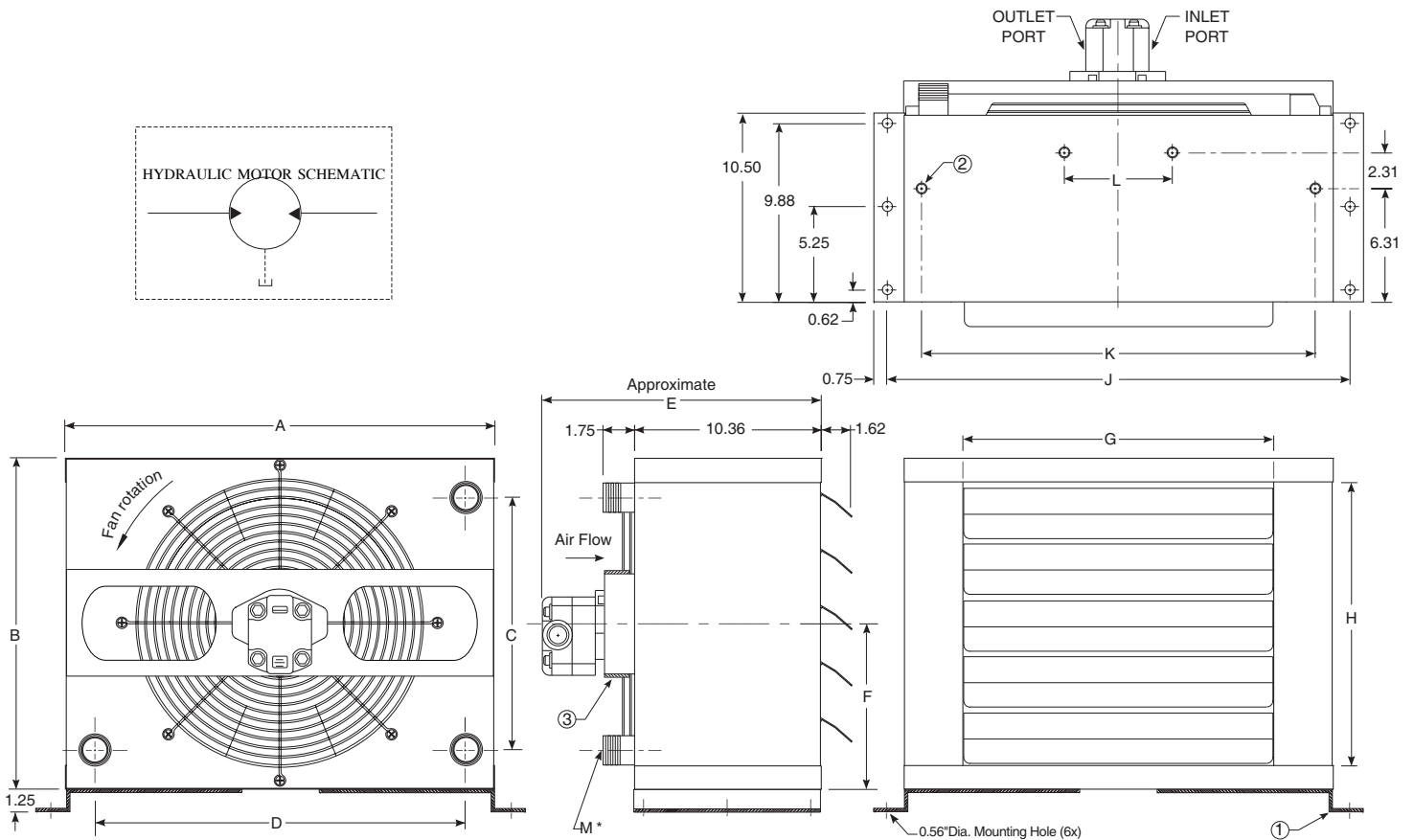

DIMENSIONS (inches)													
Model	A	B	C	D	E	F	G	H	J	K	L	M NPT	M SAE
ACHM - 5 - *	14.81	11.81	7.69	11.69	15.21	5.90	8.31	9.19	16.81	12.94	—	1.00	16 SAE
ACHM - 10 - *	19.00	13.13	8.88	15.88	15.21	6.56	12.50	10.50	21.00	17.13	—	1.00	1 5/16 - 12UN-2B
ACHM - 15 - *	20.38	15.75	11.50	17.25	15.21	7.88	13.88	13.12	22.38	18.50	—	1.00	Thread
ACHM - 20 - *	23.81	18.38	14.00	20.56	15.21	9.19	17.19	15.75	25.81	21.81	—	1.25	20 SAE
ACHM - 25 - *	26.68	23.63	19.25	23.56	15.21	11.81	20.19	21.00	28.68	24.81	—	1.25	1 5/8 - 12UN-2B
ACHM - 30 - *	31.63	27.56	23.19	28.50	15.21	13.78	25.13	24.94	33.63	29.75	11.00	1.25	Thread
ACHM - 35 - *	33.81	30.19	25.81	30.69	15.21	15.09	27.31	27.56	35.81	31.94	11.00	1.25	
ACHM - 40 - *	41.63	36.75	32.38	38.50	15.21	18.38	35.13	34.12	43.63	39.75	13.25	1.25	

* Represents options.

Notes:

- 1) Removable base mounting brackets are supplied with unit at no additional charge.
- 2) 1/2-12 UNC-2B Tabs, 4 points, 8 points on models ACHM - 30,35 & 40 (top & bottom) for optional mounting purposes.
- 3) Motor mounting bracket is rotated 90 degrees on ACHM - 5 & 10 units.
- 4) Louvers are manually adjustable. However, all units are available with a screen front as an option (specify when ordering).
- 5) All units are available with a preset 30 or 65-psi pressure bypass valve. (see note "i" in maintenance page 143)
- 6) All units can be connected in one or two pass configuration. Refer to piping instructions for detailed operating and maintenance information.

Example of a model:

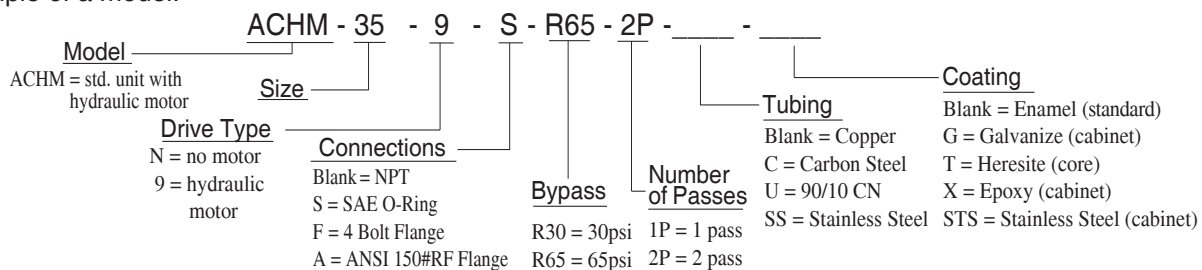

note: AIHTI reserves the right to make reasonable design changes without notice.

HYDRAULIC MOTOR DATA

Model	Motor RPM	Displacement		Required Flow		Min. pressure start / run PSIG	Case Drain SAE O-Ring	SAE Size	Side Port SAE O-Ring	Max. Continuous Pressure PSIG
		in ³ /rev	ccm/rev	GPM	LPM					
ACHM - 5 - *	1725	0.43	7.0	3.75	14.2	500 / 300	#6 9/16 -18	A	#10 7/8 -14	3000
ACHM - 10 - *	1725	0.43	7.0	3.75	14.2	500 / 300	#6 9/16 -18	A	#10 7/8 -14	3000
ACHM - 15 - *	1725	0.43	7.0	3.75	14.2	500 / 300	#6 9/16 -18	A	#10 7/8 -14	3000
ACHM - 20 - *	1725	0.43	7.0	3.75	14.2	500 / 300	#6 9/16 -18	A	#10 7/8 -14	3000
ACHM - 25 - *	1140	0.43	7.0	2.50	9.5	500 / 300	#6 9/16 -18	A	#10 7/8 -14	3000
ACHM - 30 - *	1140	0.43	7.0	2.50	9.5	500 / 300	#6 9/16 -18	A	#10 7/8 -14	3000
ACHM - 35 - *	1140	0.43	7.0	2.50	9.5	600 / 400	#6 9/16 -18	A	#10 7/8 -14	3000
ACHM - 40 - *	1140	0.43	7.0	2.50	9.5	600 / 400	#6 9/16 -18	A	#10 7/8 -14	3000

HYDRAULIC MOTOR NOTES:

- 1) Standard ACHM units are supplied with a hydraulic gear motor for the fan drive. The gear motor requires an external case drain be used during operation. The external case drain should be connected directly to hydraulic reservoir or a return line with not greater than 10PSIG back pressure. (NOTE: *Failure to properly connect and use the external case drain during motor operation could result in motor failure and external leakage of hydraulic fluid.*)
- 2) Hydraulic motor flow requirements are provided with an efficiency rating of approximately 85%. Pressure requirements are calculated theoretical minimum operating requirements.
- 3) Shaft adapters are used to bridge the differences in length between the fan and hydraulic motor.
- 4) Maximum degree of fluid contamination, class 18/15 according to ISO 4406. Therefore, it is recommended to use a filter with retention rating of B20>. For longer life, it is recommended to use class 17/14 achievable with filter B10>-100.
- 5) Fan rotation is clockwise when facing the motor shaft.
- 6) Optional displacement motors available upon request.
- 7) American industrial reserves the right to enact changes to hydraulic motor, brand, type, ratings, port sizes, or any additional non-specified attribute for standard products without notice.

COMMON DATA

Model	Air Flow		Sound Level dB(A) @ 7ft	Liquid Volume		Approx. Weight Electric		Approx. Weight Hydraulic		Serviceable Core
	CFM	m ³ /s		gal.	cm ³	lb	kg	lb	kg	
Model - 5 - *	494	.233	68	.59	2233	65	30	55	25	No
Model - 10 - *	710	.335	70	.72	2725	85	39	75	34	No
Model - 15 - *	1015	.479	70	.85	3218	95	43	85	39	No
Model - 20 - *	1555	.733	71	1.15	4352	130	59	110	50	No
Model - 25 - *	2240	1.05	72	1.52	5753	165	75	150	68	No
Model - 30 - *	3100	1.46	75	1.88	7116	190	86	175	79	No
Model - 35 - *	4370	2.06	76	2.26	8554	235	107	220	100	No
Model - 40 - *	5450	2.51	78	2.95	11166	275	125	260	118	No

- NOTES: a) * Represents the options for motor drive.
 b) To estimate the sound level at distances other than 13 feet (4 meters) from the cooler, add 6 db for each halving of distance, or subtract 6 db for each doubling of the distance.

PIPING HOOK UP *shown with relief valve*

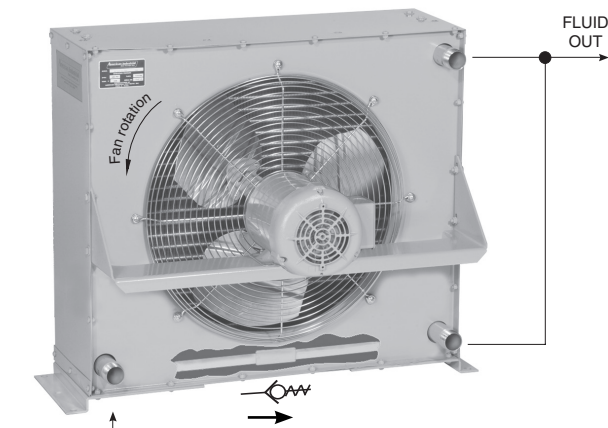

ONE PASS

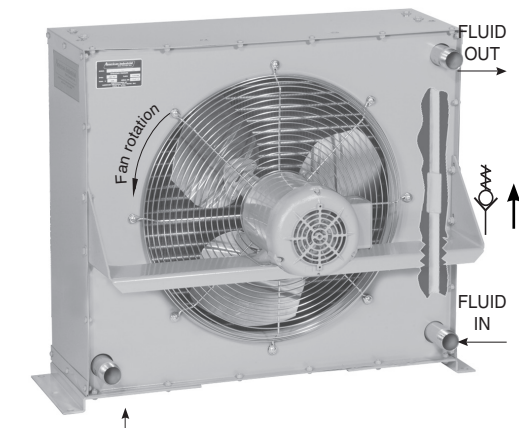

TWO PASS

note: AIHTI reserves the right to make reasonable design changes without notice.

AC, ACF & ACHM Series *installation & maintenance*

PIPING HOOK UP

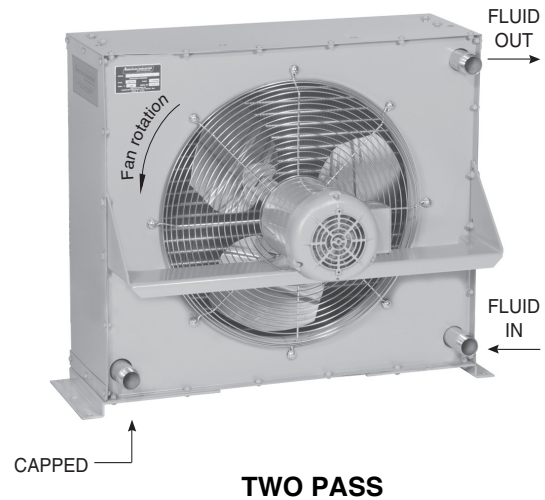
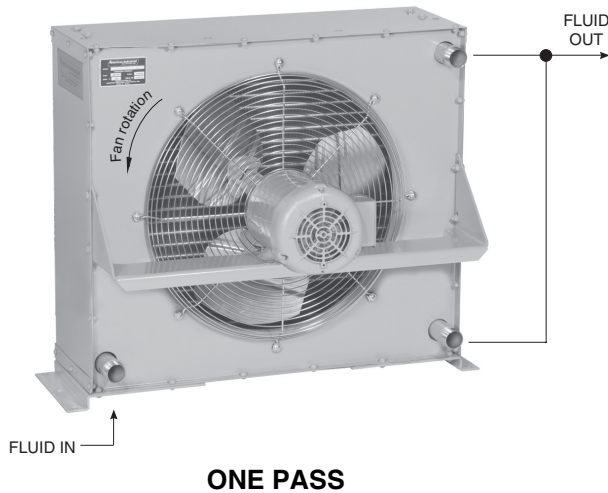

Receiving / Installation

a) Inspect unit for any shipping damage before uncrating. Indicate all damages to the trucking firms' delivery person and mark it on the receiving bill before accepting the freight. Make sure that the core and fan are not damaged. Rotate the fan blade to make sure that it moves freely. The published weight information located in this brochure is approximate. True shipment weights are determined at the time of shipping and may vary. Approximate weight information published herein is for engineering approximation purposes and should not be used for exact shipping weight. *Since the warranty is based upon the unit date code located on the model identification tag, removal or manipulation of the identification tag will void the manufacturers warranty.*

b) When handling the heat exchanger, special care should be taken to avoid damage to the core and fan. All units are shipped with wood skids for easy forklift handling

c) Standard Enamel Coating: American Industrial provides its standard products with a normal base coat of oil base air cure enamel paint. The enamel paint is applied as a temporary protective and esthetic coating prior to shipment. While the standard enamel coating is durable, American Industrial does not warranty it as a long-term finish coating. It is strongly suggested that a more durable final coating be applied after installation or prior to long-term storage in a corrosive environment to cover any accidental scratches, enhance esthetics, and further prevent corrosion. It is the responsibility of the customer to provide regular maintenance against chips, scratches, etc... and regular touch up maintenance must be provided for long-term benefits and corrosion prevention.

d) Special Coatings: American Industrial offers as customer options, Air-Dry Epoxy, and Heresite (Air-Dry Phenolic) coatings at additional cost. American Industrial offers special coatings upon request, however American Industrial does not warrantee coatings to be a permanent solution for

any equipment against corrosion. It is the responsibility of the customer to provide regular maintenance against chips, scratches, etc... and regular touch up maintenance must be provided for long-term benefits and corrosion prevention.

e) American Industrial recommends that the equipment supplied should be installed by qualified personnel who have solid understanding of system design, pressure and temperature ratings, and piping assembly. Verify the service conditions of the system prior to applying any air cooled heat exchanger series cooler. If the system pressure or temperature does not fall within the parameters on model rating tag located on the heat exchanger, contact our factory prior to installation or operation.

g) Heat exchanger should be securely fastened using the mounting foot brackets (included). All mounting holes should be used to secure unit into place. Optional horizontal mounting with vertical airflow is allowable by removing the foot brackets and using the (4 or 8) 1/2"-13 screw hard points located on the top and bottom panel for fastening. Heat exchanger unit must be set into a fabricated channel type frame with provision for additional motor support for heavy motors in conjunction with 1/2" frame fastening bolt points. Since the units are normally operated in the vertical position (horizontal airflow) reinforced motor support is suggested.

h) Connections should be made in "one pass" or "two pass" configurations exactly as indicated in the "piping hook up" illustration above. The process flow entering the "Fluid IN" port and exiting the "Fluid OUT" port eliminates air pockets and assures that the unit will stay completely flooded. Flexible hose can be applied to reduce the risk of core failure due to thermal expansion or system vibration. Piping alignment and support is required for hoses longer than four feet in length and for piping exerting more than 20 lbs of dynamic force. It is recommended that filtration be

AC, ACF & ACHM Series *installation & maintenance*

located ahead of the heat exchanger to prevent excessive backpressure and clogging.

i) With respect to the heat exchangers nozzle size, flow line sizes should be sized to handle the appropriate flow rate and system pressure drop requirements, normally flow line rates of about 8-12 feet per second and inlet pressure less than 100psig are experienced. If the flow line size is larger than the heat exchanger nozzle size, additional pressure loss beyond the published pressure loss data may occur.

j) Electric motors should be connected only to supply source of the same characteristics as indicated on the electric motor information plate. Prior to starting, verify that the motor and fan spin freely without obstruction. Check carefully that the fan turns in the correct rotation direction (normally counter clockwise) from the motor side (fan direction arrow). Failure to operate the fan in the proper direction could reduce performance or cause serious damage to the heat exchanger or other components. Fan blades should be rechecked for tightness after the first 100 hours of operation.

k) It is important to apply the catalog recommended flow rate for the hydraulic motor that corresponds with the specific model being used. A case drain is required for hydraulic motor installation. Failure to connect case drain can result in motor failure. The proper flow rate and direction to the hydraulic motor are critical to ensure fan direction and RPM. Exceeding the recommended RPM could result in fan failure and cause severe damage to the heat exchanger. See fan rotation on installation diagram

Maintenance

Regular maintenance intervals based upon the surrounding and operational conditions should be maintained to verify equipment performance and to prevent premature component failure. Since some of the components such as, motors, fans, load adapters, etc... are not manufactured by American Industrial, maintenance requirements provided by the manufacture must be followed.

a) Inspect the entire heat exchanger and motor/fan assembly for loosened bolts, loose connections, broken components, rust spots, corrosion, fin/coil clogging, or external leakage. Make immediate repairs to all affected areas prior to restarting and operating the heat exchanger or its components.

b) Heat exchangers operating in oily or dusty environments will often need to have the coil cooling fins cleaned. Oily or clogged fins should be cleaned by carefully brushing the fins and tubes with water or a non-aggressive degreasing agent mixture (*Note: Cleaning agents that are not compatible with copper, brass, aluminum, steel or stainless steel should not be used*). A compressed air or a water stream can be used to dislodge dirt and clean the coil further. Any external dirt or oil on the electric motor and fan assembly should be removed. *Caution: Be sure to disconnect the electric motor from its power source prior to doing any maintenance.*

c) In most cases it is not necessary to internally flush the

coil. In circumstances where the coil has become plugged or has a substantial buildup of material, flushing the coil with water or a solvent may be done. Flushing solvents should be non-aggressive suitable for the materials of construction. Serviceable Core® models can be disassembled and inspected or cleaned if required.

d) Most low horsepower electric motors do not require any additional lubrication. However, larger motors must be lubricated with good quality grease as specified by the manufacture at least once every 6-9 months or as directed by the manufacture. T.E.F.C. air ventilation slots should be inspected and cleaned regularly to prevent clogging and starving the motor of cooling air. To maintain the electric motor properly see the manufactures requirements and specifications.

e) Fan blades should be cleaned and inspected for tightness during the regular maintenance schedule when handling a fan blade care must be given to avoid bending or striking any of the blades. Fan blades are factory balanced and will not operate properly if damaged or unbalanced. Damaged fan blades can cause excessive vibration and severe damage to the heat exchanger or drive motor. Replace any damaged fan with an American industrial suggested replacement.

f) Air cooled exchanger cabinets are constructed using 7ga. through 18ga. steel that may be bent back into position if damaged. Parts that are not repairable can be purchased through American Industrial.

g) Coil fins that become flattened can be combed back into position. This process may require removal of the coil from the cabinet.

h) It is not advisable to attempt repairs to brazed joints of a brazed construction coil unless it will be done by an expert in silver solder brazing. Brazed coils are heated uniformly during the original manufacturing process to prevent weak zones from occurring. Uncontrolled reheating of the coil may result in weakening of the tube joints surrounding the repair area. In many instances brazed units that are repaired will not hold up as well to the rigors of the system as will a new coil. American Industrial will not warranty or be responsible for any repairs done by unauthorized sources. Manipulation in any way other than normal application will void the manufactures warranty.

i) Solely at the request of customers, American Industrial provides direct acting internal inlet port to outlet port bypass relief valves as an additional safe guard against surge flow and over pressurization of the heat exchanger. However, American Industrial does not specify, recommend, suggest, guarantee, or warrantee the internal relief valve or its performance to safe guard the heat exchanger from damage or prevent failure due to excessive flow or over pressurization. It is the ultimately the sole responsibility of the customer/user to verify with the original equipment manufacture all conditions associated with applying an additional system relief valve prior to application.