



Air Cooled Liquid Cooler Application Request:
For AOCSH Series

Email form to: sales@aihti.com or engineering@aihti.com or fax to 434-757-1810

Contact Name _____ Telephone _____ Date _____
Company Name _____ Email _____
Address: _____ Fax _____

Hot Side

Cold Side

Fluid Type _____	Ambient Air _____
Density _____ lb/ft ³	Altitude _____
Viscosity _____ cP	
If available: Thermal Conductivity _____ Btu/hr.ft.°F	
Specific Heat _____ Btu/lb.°F	
1. Flow Rate _____	1. Operating Pressure _____
2. Temperature In _____	2. Allowable Pressure Drop _____
3. Desired Temperature Out _____	ASME Code and Certified Yes <input type="checkbox"/> No <input type="checkbox"/>
4. Heat Load _____	

To properly size the heat exchanger we need 3 of the 4 parameters on the Hot Side.

Cabinet Material:	Tubing Material:	Motor
Standard : Steel <input type="checkbox"/>	Standard : Copper <input type="checkbox"/>	60Hz: 230/460 Volt, 3 Phase <input type="checkbox"/>
Options: Galvanized Steel <input type="checkbox"/>	Options: Stainless Steel <input type="checkbox"/>	115/230 Volt, 1 Phase <input type="checkbox"/>
Options: Stainless Steel <input type="checkbox"/>	Options: 90/10 Copper Nickel <input type="checkbox"/>	575 Volt, 3 Phase <input type="checkbox"/>
Coating	Fins	50Hz: 230/400 Volt, 3 Phase <input type="checkbox"/>
Standard Enameled <input type="checkbox"/>	Standard Aluminum <input type="checkbox"/>	110/220 Volt, 1 Phase <input type="checkbox"/>
Options: Gray Paint <input type="checkbox"/>	Options: Copper <input type="checkbox"/>	
Options: Epoxy Paint <input type="checkbox"/>	Optional Coating: Heresite <input type="checkbox"/>	Hydraulic Motor <input type="checkbox"/>

Comment: _____

AOC SH SERIES



AIR COOLED

LIQUID COOLERS

- Severe duty construction with OSHA guard.
- Serviceable Core®.
- Thermal capacity to 1,400 hp (1,043 Kw).
- Operating temperature of 300°F at 200 PSI.
- Electric, hydraulic, or external drive.
- Optional: built-in bypass valve.
- Can be customized to fit any applications.
- Field changeable drive from electric to hydraulic.
- Cools: Fluid power systems, rock crushers, conveyors, shredders, lubrication equipment for paper machinery, gear drives, offshore drilling equipment, etc.

AOCSH Series *dimensions with electric / hydraulic drive*

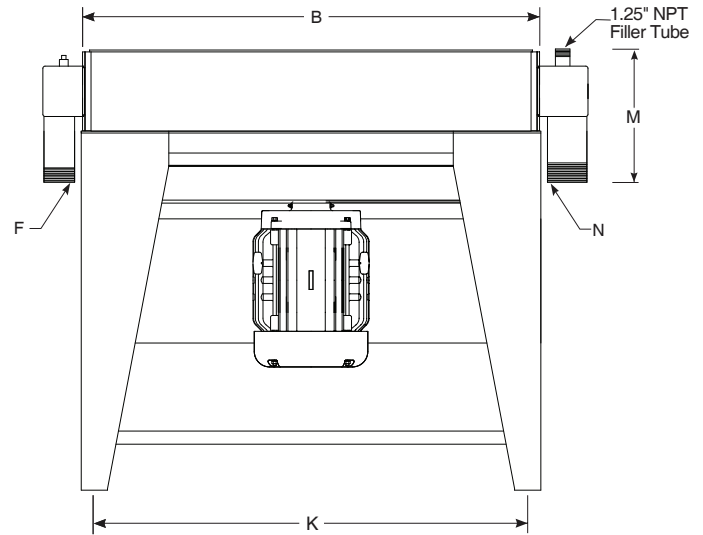
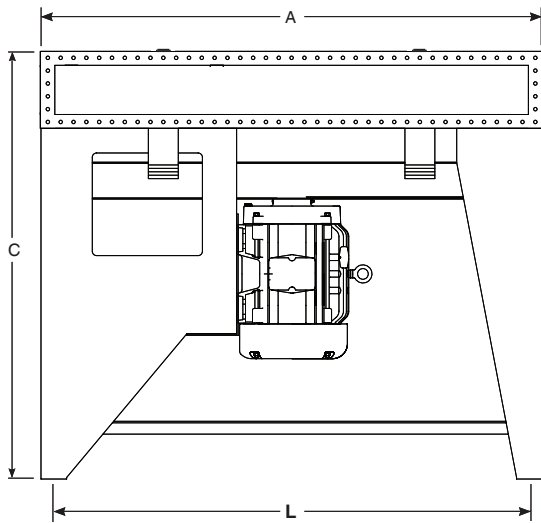
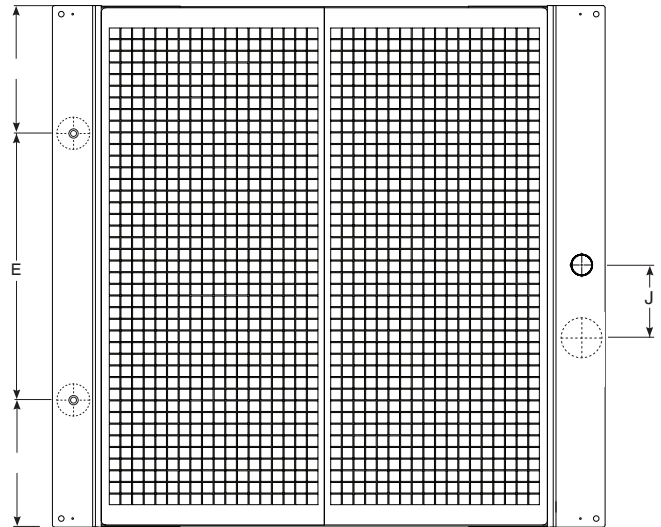

AOCSH - 1005 through AOCSH - 4030

(F* and N*) are SAE code 61 four bolt flanges

DIMENSIONS (inches)																
Model	A	B	C	D	E	F NPT	F* SAE	G	H	J	K	L	M	N NPT	N* SAE	T
AOCSH-201 - *	26.00	22.75	38.50	6.00	6.00	1.25	1.25	11.00	1.38	7.00	13.25	19.61	9.00	1.50	1.50	18.00
AOCSH-303 - *	31.25	26.75	38.50	6.00	7.00	1.25	1.25	13.00	1.88	7.00	18.48	23.61	9.00	2.00	2.00	22.00
AOCSH-453 - *	35.00	32.25	40.88	6.00	8.00	1.50	1.50	15.75	1.88	7.00	22.23	29.13	9.00	2.00	2.00	28.00
AOCSH-603 - *	41.00	37.25	40.88	6.00	10.00	1.50	1.50	18.25	2.13	7.00	28.23	34.13	9.00	2.50	2.50	32.00
AOCSH-1005-*	46.25	44.25	42.75	6.00	10.50	2.00	2.00	21.75	3.50	8.00	33.48	41.13	13.50	3.00	3.00	36.00
AOCSH-1505-*	53.25	52.25	42.75	6.00	12.50	2.00	2.00	25.75	3.50	8.00	40.48	49.13	13.50	3.00	3.00	42.00
AOCSH-2010-*	62.25	58.75	80.00	9.00	15.00	3.00	3.00	29.00	4.50	8.00	49.48	55.61	15.50	4.00	4.00	48.00
AOCSH-2515-*	70.50	66.50	52.65	37.00	16.00	3.00	3.00	32.87	4.50	8.00	57.73	63.56	15.50	4.00	4.00	54.00
AOCSH-3120-*	76.50	68.75	52.65	40.00	17.00	3.00	3.00	34.00	4.50	8.00	63.76	65.61	15.50	4.00	4.00	60.00
AOCSH-3525-*	82.75	73.25	52.87	43.00	18.00	3.00	3.00	37.00	4.50	8.00	70.00	70.11	18.00	4.00	4.00	60.00
AOCSH-4030-*	88.78	79.25	52.87	46.00	20.00	3.00	3.00	40.00	4.50	8.00	76.00	76.13	18.00	4.00	4.00	60.00

*Represents the options for motor drive.

1. The AOC SH series construction materials are identical to AOCS series, (See page 189)
2. AOC SH electric motors and hydraulic motors are identical to AOCS Series (See page 193, 195)
3. Will provide a detailed drawing of the unit upon receiving an order
4. The overall height of the heat exchanger (C dimension) can change to meet any application

Example of a model:

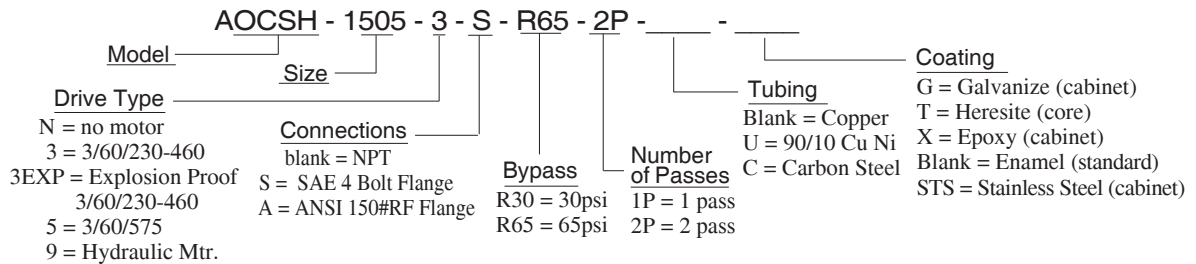

COMMON DATA

Model	Air Flow		Sound Level dB(A) @ 13ft	Liquid Volume		Weight Electric		Weight Hydraulic		Serviceable Core™
	CFM	m³/s		gal.	cm³	lb	kg	lb	kg	
AOC SH-201 -*	3000	1.41	77	1.7	6435	200	91	185	84	Yes
AOC SH-303 -*	4380	2.07	82	3.8	14383	310	141	260	118	Yes
AOC SH-453 -*	5920	2.79	78	4.8	18168	490	222	410	186	Yes
AOC SH-603 -*	8750	4.13	80	6.1	23089	580	263	490	222	Yes
AOC SH-1005-*	12650	5.97	84	7.7	29145	690	313	575	261	Yes
AOC SH-1505-*	16150	7.65	87	10.4	39364	910	413	1025	465	Yes
AOC SH-2010-*	23350	11.73	92	22.8	86298	1280	580	1062	482	Yes
AOC SH-2515-*	32000	15.00	95	27.5	104088	1610	730	1320	598	Yes
AOC SH-3120-*	39000	18.40	99	31.9	120742	1810	821	1483	673	Yes
AOC SH-3525-*	46000	21.71	99	47.0	177895	1980	898	1622	736	Yes
AOC SH-4030-*	54000	25.48	99	47.0	185466	2150	975	1762	799	Yes

Accessories for Air / Liquid Application

For detailed information and part number see Page 269

Electrical Temperature controller with Bulb Well Assembly (for Air / Liquid Coolers)

Part Number	Description
310-4001	TC-511 with 5-Foot Capillary Tube & Bulb Well
310-4002	TC-511 with 20-Foot Capillary Tube & Bulb Well
310-2005	Replacement Bulb Well TC-511



“3-Way” Thermostatic Valve

For detailed information and model selection see page 270

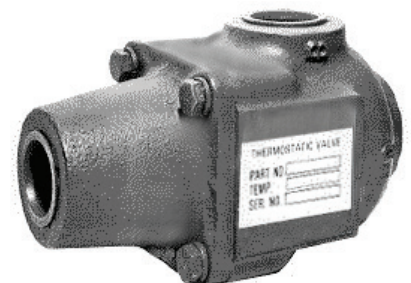

note: AIHTI reserves the right to make reasonable design changes without notice.